

**Aqua-World**

**Assembly / Installation Manual for Oval  
and Round Satinwood Swimming Pools**



# TABLE OF CONTENTS

---

PART 1	INTRODUCTION .....	2
PART 2	SELECTING A LOCATION FOR POOL INSTALLATION .....	3
PART 2A	PREPARING THE BASE FOR AN OVAL POOL .....	4
PART 2B	PREPARING THE BASE FOR A ROUND POOL.....	9
PART 3A	ASSEMBLING THE OVAL POOL BASE AND SIDE SUPPORTS.....	12
PART 3B	ASSEMBLING THE ROUND POOL BASE .....	20
PART 4	ASSEMBLING THE POOL WALL AND LINER.....	21
PART 5	INSTALLING THE TOP RAILS AND VERTICALS.....	26
PART 6	SAFETY INSTRUCTIONS.....	29
PART 7	USING THE POOL .....	30
PART 8	POOL MAINTENANCE.....	30
PART 9	WINTERISING THE POOL .....	31

## ANNEXES:

A) INSTRUCTIONS TO USE FOR FELT PAD .....	36
B) INSTRUCTIONS FOR ASSEMBLY AND USE OF THE SKIMMER.....	34
C) POOL MAINTENANCE.....	37

### Important:

Please note that the installation instructions may differ slightly for oval and round pools. Where these differences are marked, the instructions are divided into two parts – Part A and Part B. Where instructions contain only a slight difference for an oval pool, this is mentioned in the text and indicated by a “strip” at the margin of the relevant paragraph.

# PART 1 - INTRODUCTION

---

## 1. READ THE INSTRUCTIONS

**Read all instructions completely before you begin.**

These instructions explain how to install your pool. Simply follow the step-by-step directions specified in the instructions. Please note that **Part 6** includes **Safety Instructions** and **Parts 7, 8 and 9** include instructions to help you keep your pool clean and in good shape, year after year. Be sure to read the **Safety Instructions** carefully and make sure everyone who uses your pool reads and understands them.

**Note: The illustrations shown here may not correspond exactly to your pool, but are designed to aid the installation instructions. The manufacturer reserves the right to make changes.**

## 2. PREPARE THE NECESSARY TOOLS AND EQUIPMENT

Before starting pool assembly, please prepare the necessary tools. You will need:

- A spade, pick, rake, shovel and wheelbarrow for moving soil and sand;
- A wooden block, about 5 x 10 cm, whose length is longer than one half of the pool, wooden pins, wooden stakes 2.5 x 2.5 cm with a flat upper end and approximately 15 cm long, a bag with flour or fine sand, a ball of twine, knife, spirit level, measuring tape, hammer and nails for the measurement and preparation of a flat base;
- Paving blocks for reinforcing the base under the pool structure (see Part 2);
- Sieved sand for levelling the base and for creating corner filling (see Part 3 of the instructions);
- Phillips screwdriver and a flat bladed screwdriver, combined pliers, textile adhesive tape (for carpets) with a width of 50 mm, if possible, knife, clothes pegs for the pool assembly.

**Note:** With regard to the wooden stakes, we recommend you to pre-bore a sufficiently large and deep hole (See Part 2, Preparing the base). Wooden pins may be replaced e.g. with large nails. Before assembling the pool, we recommend you assemble the stepladder, as this will come in handy during pool assembly, when it is necessary to enter and exit the pool. The instructions for stepladder assembly can be found in the stepladder kit.

## 3. CHOOSE A SUITABLE DAY FOR POOL ASSEMBLY

Ideally, choose a sunny day for assembly. Do not attempt to assemble the pool when it is windy. You will require the assistance of at least one adult.

## 4. REPLACEMENT PARTS AND SERVICING

Should you need advice, or if you require pool servicing, or to obtain a replacement part, please contact your dealer. Use original replacement parts for maintenance and repairs.

## 5. WARRANTY TERMS

The Warranty Terms and Conditions are provided for in the Dealer's Warranty Certificate.

# PART 2 – PREPARING THE LOCATION

## SELECTING A LOCATION FOR POOL INSTALLATION

---

### 1. TERRAIN

Pay close attention when selecting the right location for your pool:

- Choose an area of the correct dimensions, which is as flat and level as possible.
- Choose a sunny spot on dry, firm earth — **do not install the pool** on asphalt, tarmac, sand, gravel, peat moss, cultivated ground, wood, or on a wet surface, or above water reservoirs, cesspools, gully holes, etc.
- Check to see that the site is free of plants which may grow up through your pool liner. If there are plants, we recommend you treat the site with a herbicide prior to commencing preparation of the ground, or lay a black geotextile liner over the ground.
- Sloping areas must be levelled by digging away high spots, **not by filling low spots**.
- The pool is designed in such a way that it can be partly embedded into earth, on condition that certain criteria have been met. Your pool dealer can provide professional advice on the requirements for embedding your pool.

### 2. PLACES TO AVOID

**Do not locate your pool:**

- Near to areas and objects accessible to children or animals and by which they might enter the pool accidentally. Otherwise precautions must be taken to prevent this.
- On top of grass, stones and roots. Grass will rot underneath the pool liner, whilst stones and roots will damage the pool liner.
- Near to trees and tall shrubs. Leaves and other impurities can fall directly into the pool and add to contamination.
- Under overhanging power supply lines and clothes line.
- Near areas with poor drainage. The pool area may become flooded with water.
- On areas recently treated with oil-based weed killers, chemicals or fertilizers. In this case it is necessary to use a pool liner made of geotextile.

### 3. PLAN AHEAD

- Will you be adding an adjacent deck later? Be sure to leave room.
- Be sure that any surrounding vegetation (trees, bushes) will not grow and start to shade your pool.
- Will you be using pool accessories or other appliances that need electricity? Locate your pool in such a manner that it will be possible to install these systems in accordance with safety instructions (see the instructions for this equipment). Installations of electrical sockets and circuit breakers should be performed by appropriately qualified persons only.

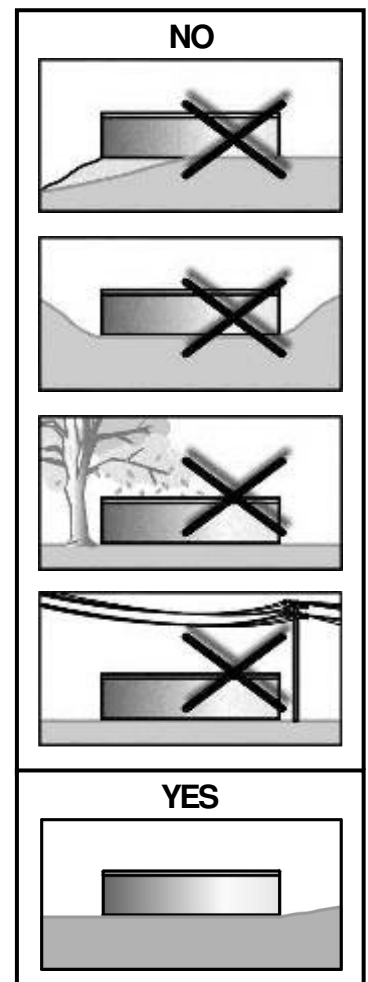

### 4. PROCEED WITH ASSEMBLY EITHER AS PER PART 2A OR PART 2B

Continue to assemble your pool either according to Part 2A for oval pools or Part 2B for round pools.

# PART 2A

## PREPARING THE BASE FOR AN OVAL POOL

### DIMENSIONAL SKETCHES FOR AN OVAL POOL

Pool size:			
	3.7x5.5 m	3.7x7.3 m	4.6x9.1 m
R	183 cm	183 cm	299 cm
S	200 cm	200 cm	259 cm
L	91.5 cm	183 cm	229 cm
M	91.5 cm	61 cm	77 cm
N	-	122 cm	151 cm
P	183 cm	366 cm	457 cm
T	263 cm	263 cm	309 cm
W	295 cm	295 cm	340 cm
X	183 cm	183 cm	229 cm
Y	204 cm	258 cm	323 cm
Z	309 cm	347 cm	410 cm

**3.7 x 5.5 m**

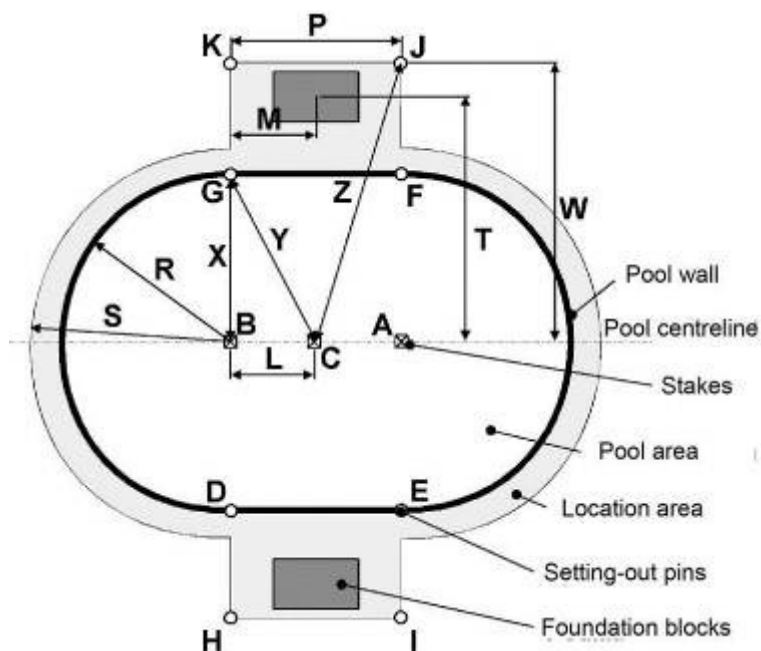

**3.7 x 7.3 m  
6.4 x 9.1 m**

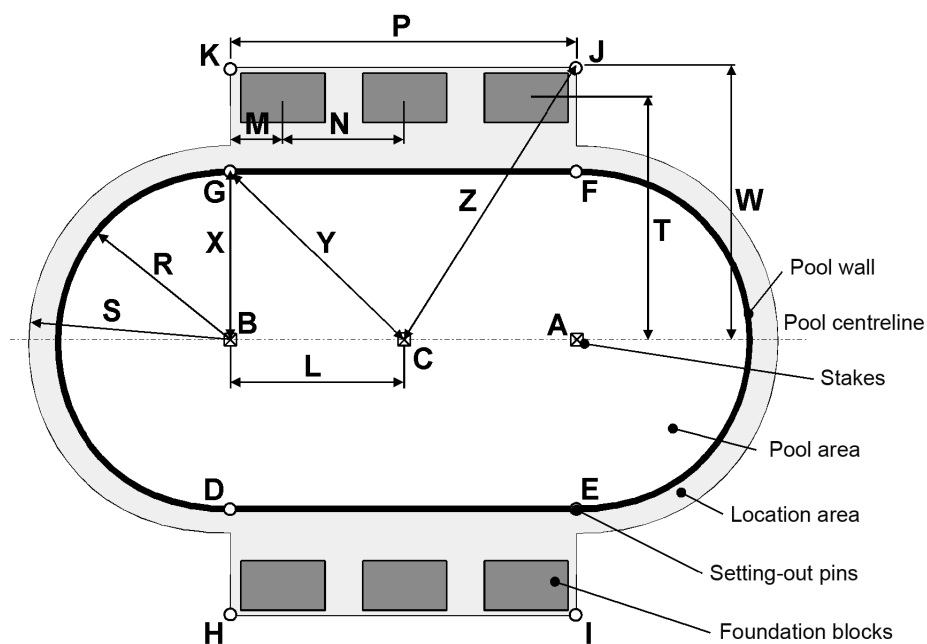

A-B-C ... stakes with a flat upper end  
D-E-F-G-H-I-J-K ... setting-out pins

**Important: The area under the pool must comply with the following conditions:**

- 1) **It must be level,**  
This means to a tolerance of maximum of 2.5 cm.
- 2) **It must be covered with a thin layer of sieved sand,**  
This means that sand will level any small flatness differences in the area arising after the use of work tools (pick, hoe, etc.). The layer should not exceed 2cm and must cover the entire area of the pool.
- 3) **It must be compacted,**  
It should be sufficiently firm that a person weighing at least 80 kg leaves no visible traces on the surface.

### 1. MARK OUT THE AREA

Look at page 4 and prepare the location according to the diagram corresponding to your pool type.

- a. Drive two pins [A] and [B] into the ground (Fig. 2A-1). These pins will both be on the centreline of your pool. The distance between the pins is equal to dimension **P** on the pool drawings (page 4).
- b. Use a length of string tied between pin [A] and a can of sand or lime, flour, etc., and mark a circle on the ground. Next, do the same for pin [B]. Choose the length of string corresponding to dimension **S** in the table on page 4 with regard to appropriate size of the pool. The radius of the circles will be at least 15 cm bigger than the pool. (Fig. 2A-2)
- c. Join the two pins [A] and [B] with a piece of string. Use this string as a guide to mark the centreline of the pool.
- d. Replace the two pins [A] and [B] with two flat-topped stakes. Their overlapping section should be at least 25x25 mm and their length at least 15 cm. Drive them down flush with the ground surface. (Fig. 2A-3)
- e. Drive another flat-topped stake [C] (of the same parameters) exactly halfway between the two pins [A] and [B] on the pool centreline. Drive it down flush with the ground surface. (Fig. 2A-3)
- f. Join the two circles with straight lines to make an oval. Use setting-out pins and a piece of string as a guide for marking of the lines (with sand, lime, etc.). (Fig. 2A-4)
- g. Mark rectangles along both straight sides of your oval (Fig. 2A-4). Use setting-out pins and string as a guide to mark straight lines. Use the chart on page 4 to find the correct dimensions **W** for the appropriate size of the pool.

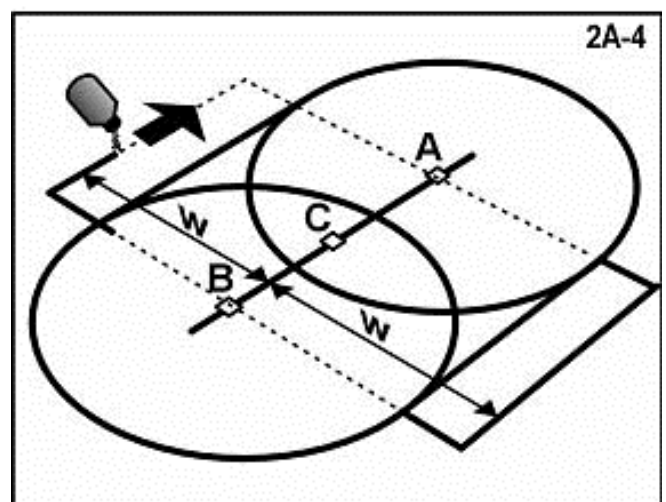
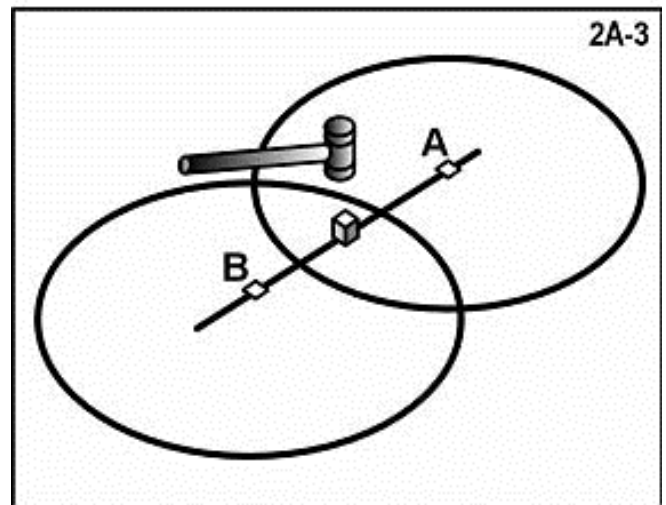
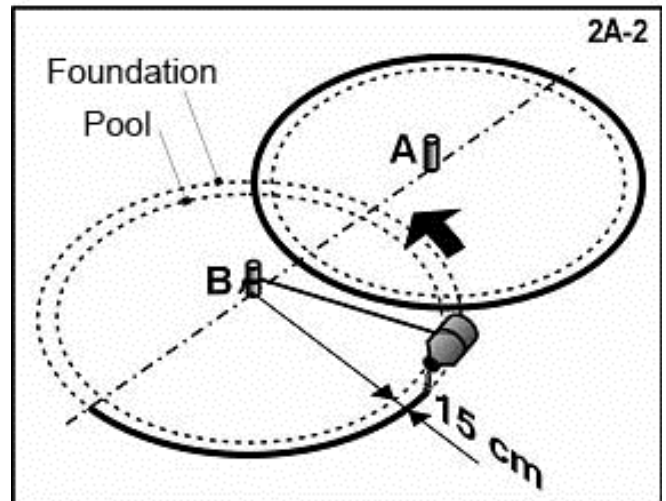
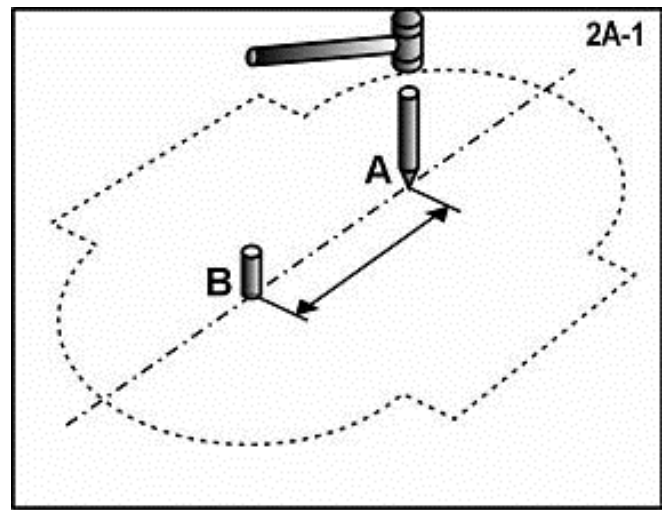

## 2. REMOVE THE GRASS SODS

- Remove carefully all grass sods and plants from the area marked out, to a depth of 10-15 cm (Fig. 2A-5).
- Remove any sticks, stones and roots from the area marked out.
- If you intend to embed the pool into the ground, it is necessary to perform excavation work to the required depth in accordance with the special embedding requirements.

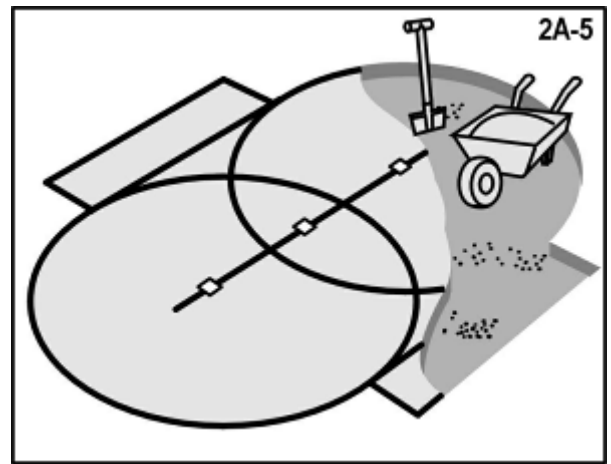

## 3. MAKE THE AREA MARKED OUT FLAT, LEVEL AND COMPACTED

**Remember: Your pool must be perfectly level.** Any deviation in the level plane must not exceed 25 mm (Fig. 2A-9).

- Drive all three stakes to the ground level and measure them equidistantly with a spirit level. They must be placed in a level plane.
- Use a 5x10 cm block whose length corresponds to the **S** dimension in the table on page 4 for the appropriate size of the pool. Drive a sufficiently long nail into one end. Use the nail to keep the end of the block on the stake when you are rotating the block in the circle (Fig. 2A-7).
- Drill a hole in the centre of stakes [A], [B] and [C], sufficiently large and deep so that the nail can rotate in it (Fig. 2A-6). It must be possible to pull out the nail easily from the stake and enable it to rotate freely around its own axis.
- Now insert the block with the nail into the [A] stake hole. Put the spirit level onto the block and shift the block into the circle around the end driven to the stake and identify the high spots and low areas this way (Fig. 2A-8).
- Remove all the high spots** with a shovel, hoe or rake. **Remember**, your pool must be level to a tolerance of 25 mm across the pool (Fig. 2A-9). If necessary, adjust the height of the stakes [A], [B] and [C] and keep scraping away soil until the area is level.
- Do not fill in low areas** (Fig. 2A-10). Filling will create an unsafe foundation for your pool. Holes from small stones and small dips and hollows may be filled in, but the soil must be hard-packed with a tamping tool.
- Remove the 5x10 cm block from the stake [A] and insert it into the second one [B] and then also into the third stake [C] on the centreline. Repeat steps a. to f. until the whole oval area is level.
- Level the areas marked at either side of the oval in the same way.

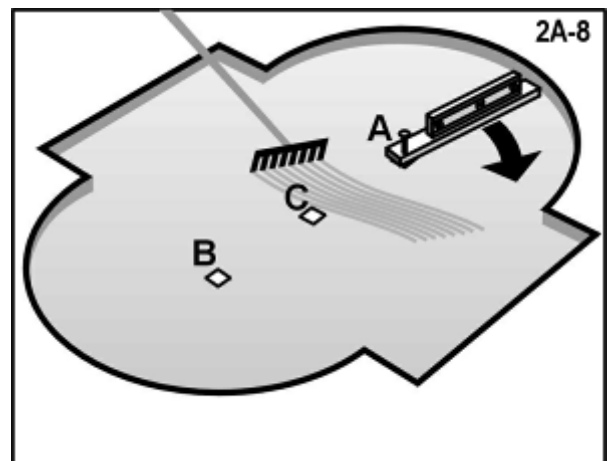
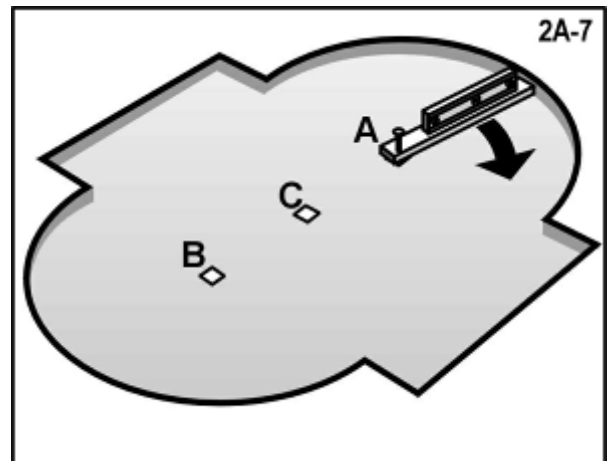
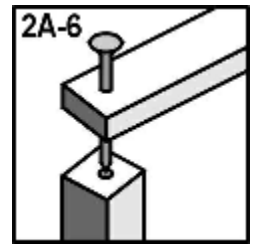

- i. **In order to ensure the future stability of the pool it is now necessary to compact the base by using a tamping tool.** If the base is not compacted, it can settle down under the pressure of the filled pool and thus cause the pool to collapse. Fill in and compact the low areas.
- j. Check the area where the pool wall will be situated again. Make sure that there are not any high spots or low areas there. The bottom edge of the pool wall must be flat and level on the ground.

**Hint:** Walk on the surface. No traces should be visible on a properly compacted surface.

Remember: The outer 30 cm of the cleared oval area must be perfectly flat (Fig. 2A-11). **The bottom edge of the pool must rest flat on the ground and have no gaps under it.** Ensure this area is perfectly flat, level and compacted.

#### 4. SETTING-OUT PINS

- a. Drive setting-out pins into the points [D], [E], [F], [G], [H], [I], [J], [K] as per the appropriate chart on page 4. Measure the distance properly according to the dimensions in the chart. These setting-out pins will help you construct the pool base.

**Hint:** It is also possible to use long nails instead of wooden pins.

- b. Pass a string between pins [H] and [I], and between pins [J] and [K].

**Important:** If you are constructing the pool on a poured concrete slab, do not install foundation blocks as described below. Nevertheless, we recommend drawing the pool centreline on the concrete area and marking the position of all setting-out pins according to the appropriate dimensional chart. This will make it easier for you to construct the pool base.

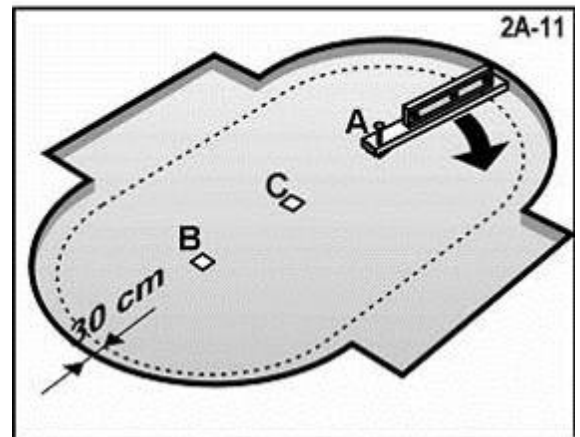
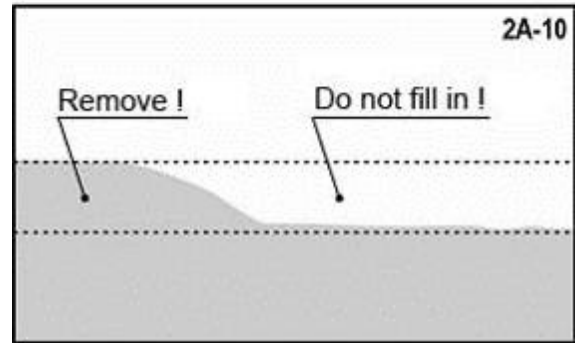
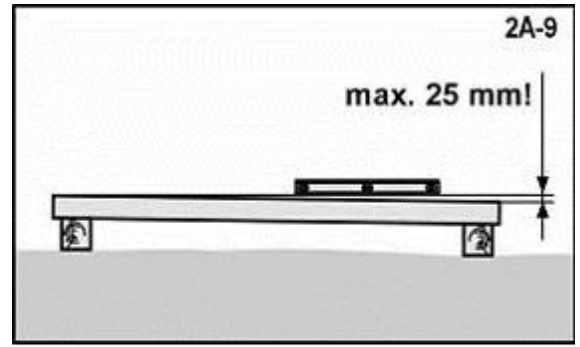

## 5. FOUNDATION BLOCKS

Foundation block (a concrete paving slab) must be laid under each inclined wall supports along the pool. Use as large foundation blocks as possible, e.g. 50x50x5 cm or 60x40x5 cm.

- a. Foundation blocks under the inclined wall supports must be installed in such a manner that the distance between the block centre and pool wall is about 80 cm.
- b. Please mark the ground spots for installation of blocks and excavate as per the dimensional chart of the corresponding pool (see page 4). Compact the excavation pit bottom. Use a thin layer of sand or finely crushed aggregate as a sub-base material.

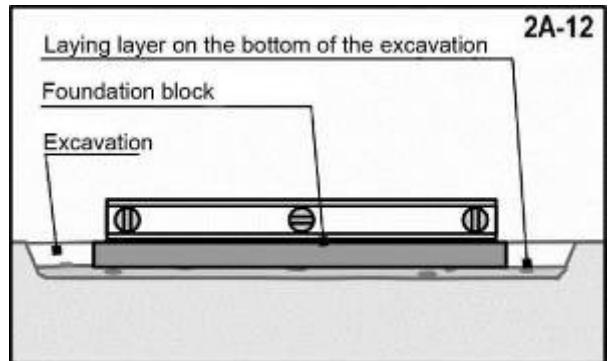

- c. All foundation blocks must be embedded into the ground in such a manner that their upper surfaces are flat with the plane of the compacted foundation area of the pool.
- d. Use a spirit level to ensure that the foundation blocks are perfectly horizontal and flat with the ground (Fig. 2A-12). Use a spirit level placed on the 5x10 cm block to check whether the upper surfaces of the adjacent foundation blocks are in one plane. After setting all blocks perform their backfill with sand or crushed aggregate (Fig. 2A-13). Compact the backfill material.

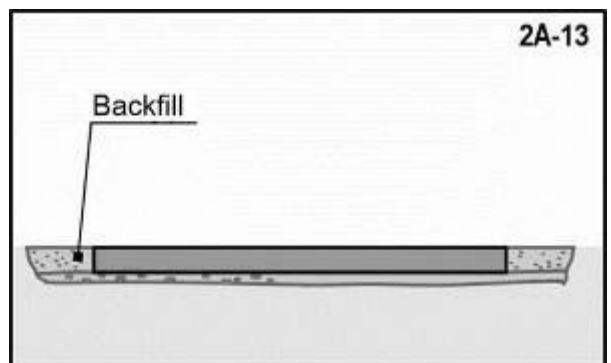

- e. In order to increase the stiffness of the foundation, it is possible to place the foundation blocks under the inclined buttresses into the laying layer made of concrete. The excavation must then be approximately twice deeper than the thickness of the paving block used, and on each side approximately 5 cm wider than the block. Use concrete for both the laying layer and backfill.

**Important:** Level the foundation blocks to one plane, as described in Step b., before the concrete gets hard. Wait until the concrete hardens before proceeding with the pool assembly.

- f. Remove all setting-out pins. Leave the stakes in place for the time being so that dimensional checks can be made during assembly.

**WARNING:** Ensure sufficient drainage of the area around the pool in order to avoid erosion of the base.

## 6. PROCEED WITH THE ASSEMBLY IN ACCORDANCE WITH PART 3A OF THE INSTRUCTIONS

# PART 2B

## PREPARING THE BASE FOR A ROUND POOL

**Important: The area under the pool must comply with the following conditions:**

- 1) **It must be level,**  
This means to a tolerance of maximum of 2.5 cm.
- 2) **It must be covered with a thin layer of sieved sand,**  
This means that sand will level any small flatness differences in the area arising after the use of work tools (pick, hoe, etc.). The layer should not exceed 2cm and must cover the entire area of the pool.
- 3) **It must be compacted,**  
It should be sufficiently firm that a person weighing at least 80 kg leaves no visible traces on the surface.

### 1. MARK OUT THE AREA

- a. Drive a pin into the ground at the point which should be the centre of the pool (Fig. 2B-1).
- b. Use a length of string tied between the pin and a can of sand or lime, flour, etc., and mark a circle on the ground. The radius of the circle will be at least 15 cm bigger than that of the pool. (Fig. 2B-2). The length of the string for the corresponding pool size is shown in the table.

Pool size (diameter)	String length	Block length
4.6 m (15')	250 cm	250 cm
5.5 m (18')	300 cm	300 cm
6.4 m (21')	350 cm	350 cm
7.3 m (24')	390 cm	390 cm

### 2. REMOVE THE GRASS SODS

- a. Remove carefully all grass sods and plants from the area marked out, to a depth of 10-15 cm (Fig. 2B-3).
- b. Remove any sticks, stones and roots from the area marked out.
- c. If you intend to embed the pool into the ground, it is necessary to perform excavation work to the required depth in accordance with the special embedding requirements.

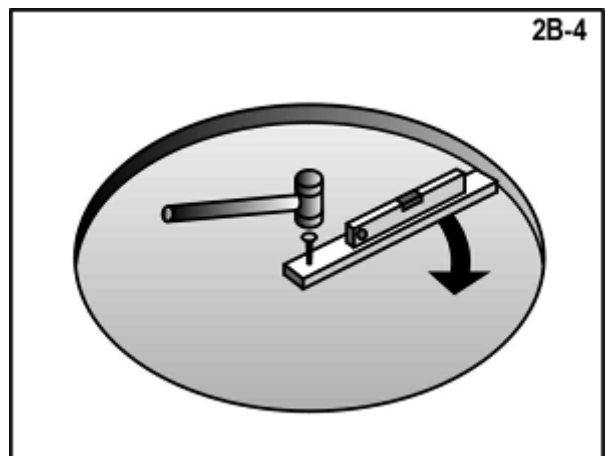
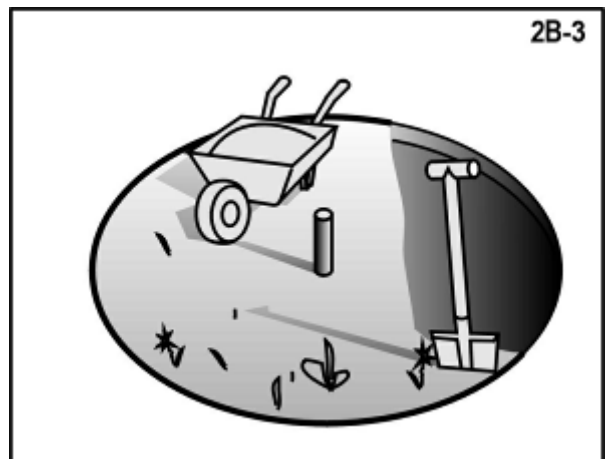
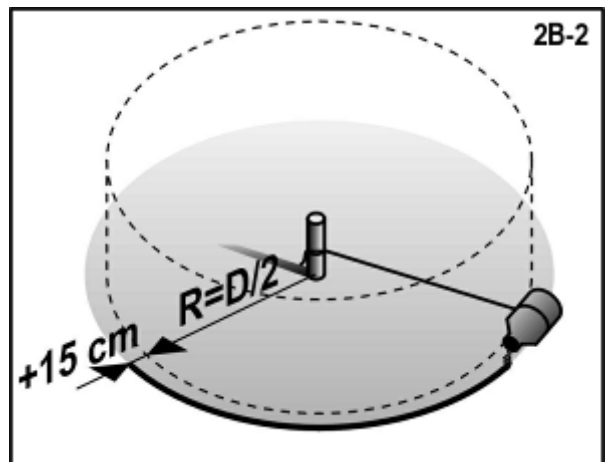
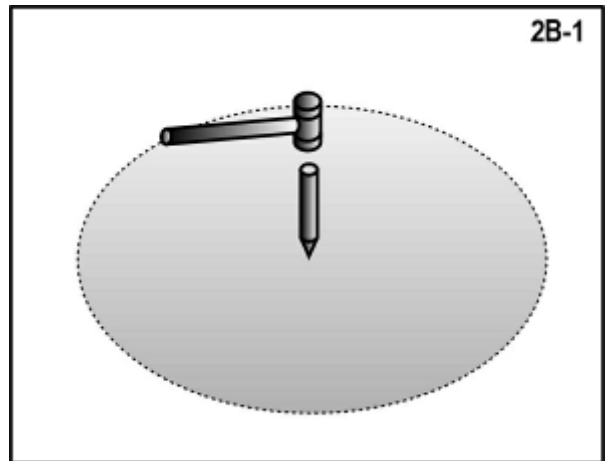

### 3. MAKE THE AREA MARKED OUT FLAT, LEVEL AND COMPACTED

**Remember: Your pool must be perfectly level.** Any deviation in the level plane must not exceed 25 mm (Fig. 2B-6).

- Replace the pin with the flat-topped stake with a cross-section of at least 25x25 mm and a length of at least 15 cm. Drive it down flush with the ground surface.
- Use a 5x10 cm block whose length corresponds to the size of the pool (see the above table). Drive a sufficiently long nail into one end. Use the nail to keep the end of the block on the stake when you are rotating the block in the circle (Fig. 2B-4).
- Drill a hole in the centre of the stake, sufficiently large and deep so that the nail can rotate in it. It must be possible to pull out the nail easily from the stake and enable it to rotate freely around its own axis.
- Now insert the block with the nail into the stake hole. Put the spirit level onto the block and shift the block into the circle around the end driven into the stake and identify the high spots and low areas this way (Fig. 2B-5).
- Remove all the high spots** with a shovel, hoe or rake. **Remember**, your pool must be level within a tolerance of 25 mm across the pool (Fig. 2B-6).
- Do not fill in low areas** (Fig. 2B-7). Filling will create an unsafe foundation for your pool. Holes from small stones and small dips and hollows may be filled in, but the soil must be hard-packed with a tamping tool.
- In order to ensure the future stability of the pool it is now necessary to compact the base by using a tamping tool.** If the base is not compacted, it can settle down under the pressure of the filled pool and thus cause the pool to collapse. Fill in and compact the low areas.

**Hint:** Walk on the surface. No traces should be visible on a properly compacted surface.

Remember: The outer 30 cm of the cleared oval area must be perfectly flat (Fig. 2B-8). **The bottom edge of the pool must rest flat on the ground and have no gaps under it.** Ensure this area is perfectly flat, level and compacted.

### 5. PROCEED WITH THE ASSEMBLY ACCORDING TO PART 3B OF THE INSTRUCTIONS

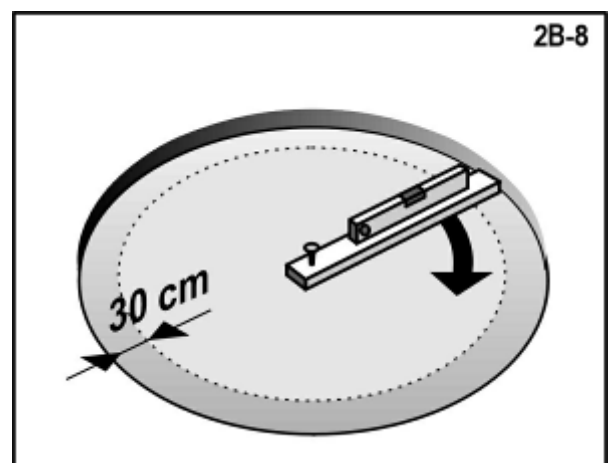
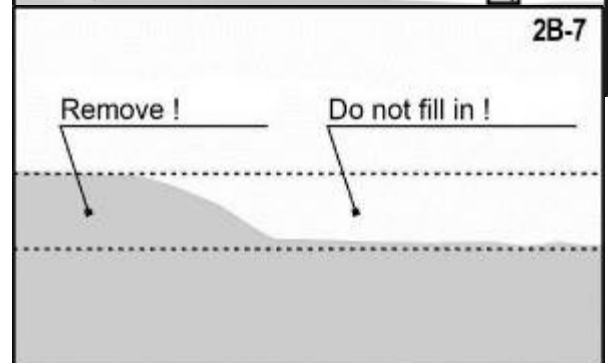
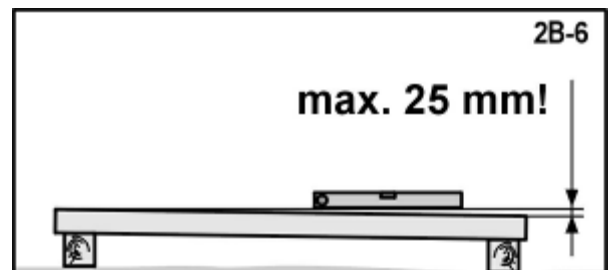
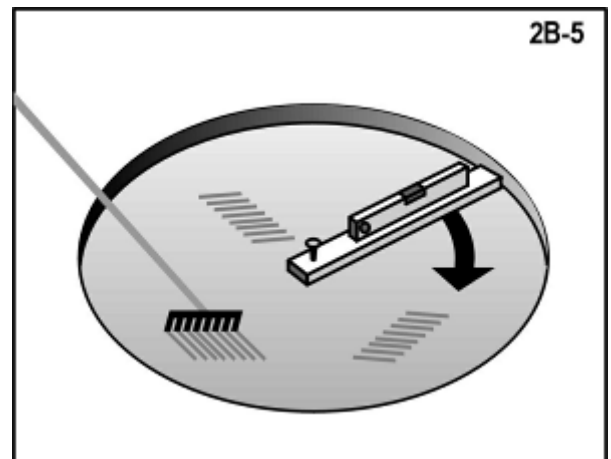

# PART 3A

## ASSEMBLING SIDE SUPPORTS OF THE OVAL POOL

### 1. PREPARING STRAPPING BELTS

- a. Remove the contents from the strapping belt box. Unfold the belts [8] and lay them flat. Carefully align all curved and bent parts.
- b. Place the strapping belts [8] in parallel to each other so that the ends of them can be placed on the surface area of the foundation blocks (Fig. 3A-1). The end of the strapping belt must be at least 15 cm from the end part of the block (Fig. 3A-2).

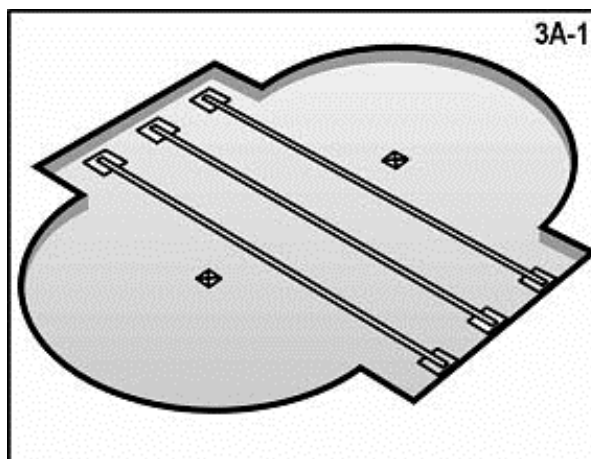

- c. Install the clamp of each inclined support [16] on both ends of the belts [8], as per Figure 3A-3. Attach it with four bolts [21] and nuts [10]. The nuts should be clamp side. Tighten the screw connections firmly. (**Legend: foundation block**).

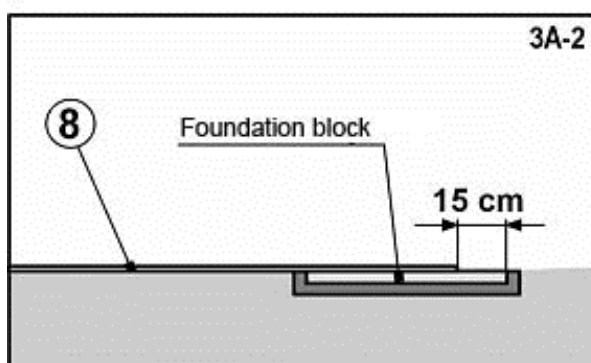

- d. Make sure that the strapping belts are laid out **parallel and level**. The distance between the strapping belts corresponds to dimension **N** in the table on page 4 for the appropriate pool size.

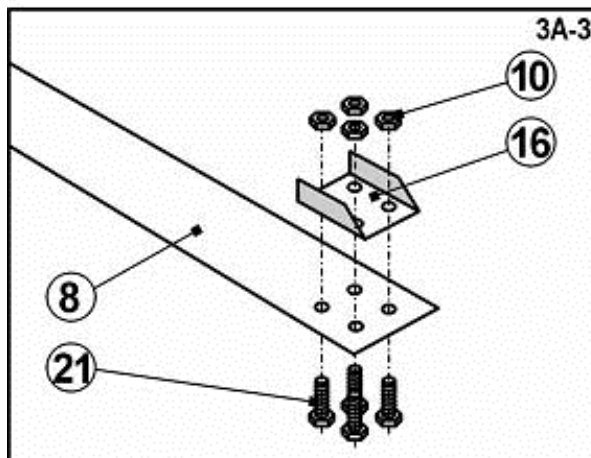

### 2. INSTALL THE BASE METAL SHEET AND VERTICAL SUPPORTS

- a. With the help of a straight edge (you can use the base metal sheet) level the surface area on which the base metal sheet will be placed.
- b. Compact the surface area, fill in any possible low areas and compact again. The surface area must be perfectly level.
- c. Raise the strapping belt [8] slightly and insert four bolts [21] (Fig. 3A-4) into the holes in the strapping belt **from underneath**.

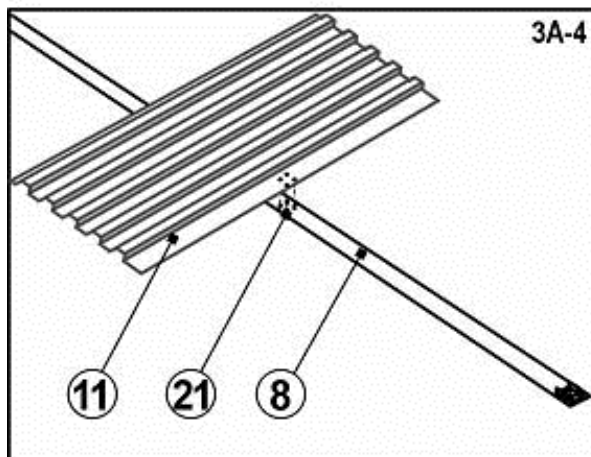

d. Put the base metal sheet [11] and the bracket [23] onto the bolts, and screw and tighten the nuts [10] (Fig. 3A-4 and 3A-5).

e. Attach the vertical support [9] to the cup [23] and screw both the parts together with the help of bolts [21] and nuts [10] (Fig. 3A-6).

f. Make sure that there is a clearance of approximately 2mm (Fig. 3A-7) under the side lower edge of the vertical support.

g. Tighten the screw connections firmly.

h. Repeat steps a. – g. for all vertical supports.

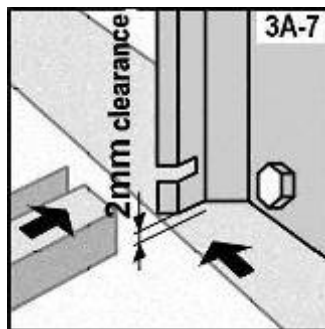
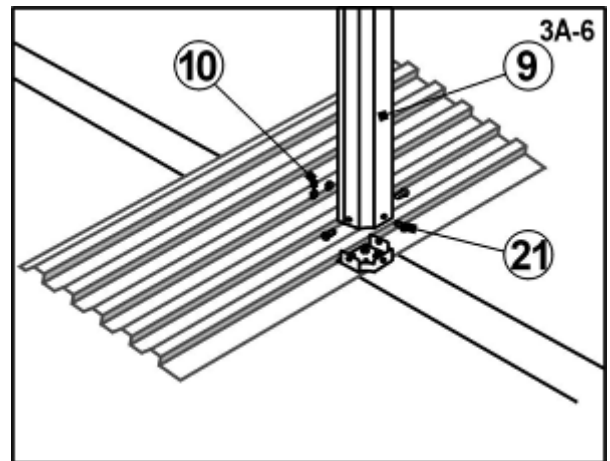
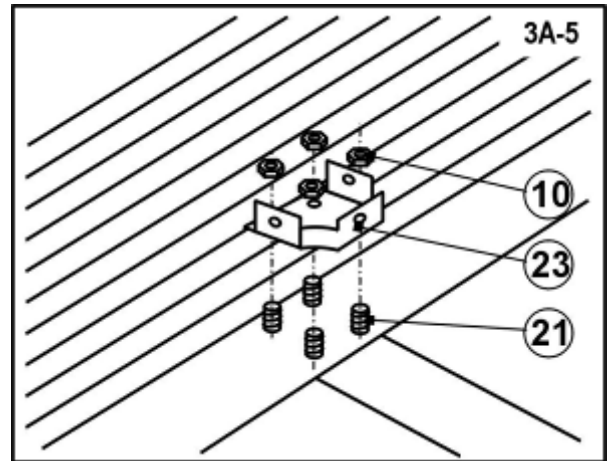

### 3. INSTALL INCLINED SUPPORTS

a. Insert the inclined support [15] with the locking mechanisms into the holes in the vertical supports [9]. First put the support into a horizontal position (Fig. 3A-8) and insert it into the vertical support. Then press upwards onto the connection and incline the other end towards the ground (Fig. 3A-9 and 3A-10).

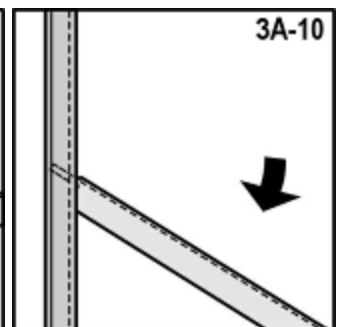
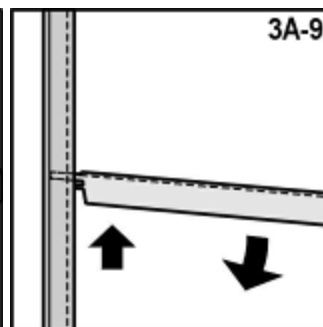
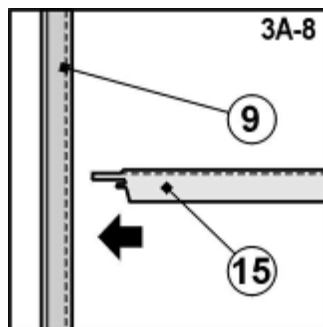

**Very important:** Ensure continuous pressure is maintained upwards on the connection of the vertical and inclined support whilst you are inclining the other end of the inclined support towards the ground.

b. Align the holes in the lower end of the inclined support [15] in one axis with the holes in the inclined clamp [16] attached on the strapping belt end [8]. Put two long bolts [26] (Fig. 3A-11) through the holes aligned this way. Screw nuts [10] onto the bolts and tighten the connections but do not over-tighten them in order to the parts from becoming misshapen.

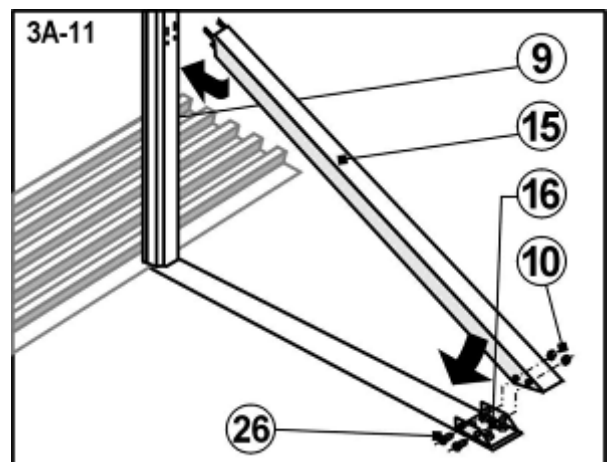

c. When installing the inclined supports, make sure that the locking mechanism in the vertical [9] and inclined supports [15] has not released.

#### 4. IDENTIFY LOWER RAILS

Each type of oval pool has different lower rails [13]. These are rails of types A, B, C and end rails. For the purpose of easy identification, these rails are marked with colours and part numbers. Please identify the rails and their quantity according to the table below and Figure 3A-12.

Pool size	Type C	Type A	Type B	End Rail
3.7 x 5.5 m (12' x 18')	none	4 – blue (1460134)	none	6 – without colours (1460061)
3.7 x 7.3 m (12' x 24')	4 – white (1460105)	4 – black (1460135)	none	6 – without colours (1460061)
4.6 x 7.3 m (15' x 24')	2 – white (1460105)	4 – red (1460136)	none	8 – without colours (1460062)
4.6 x 9.1 m (15' x 30')	4 – green (1460033)	4 – red (1460136)	none	8 – without colours (1460062)
5.5 x 10.0 m (18' x 33')	4 – green (1460033)	4 – red (1460136)	4 – yellow (1460064)	6 – without colours (1460063)

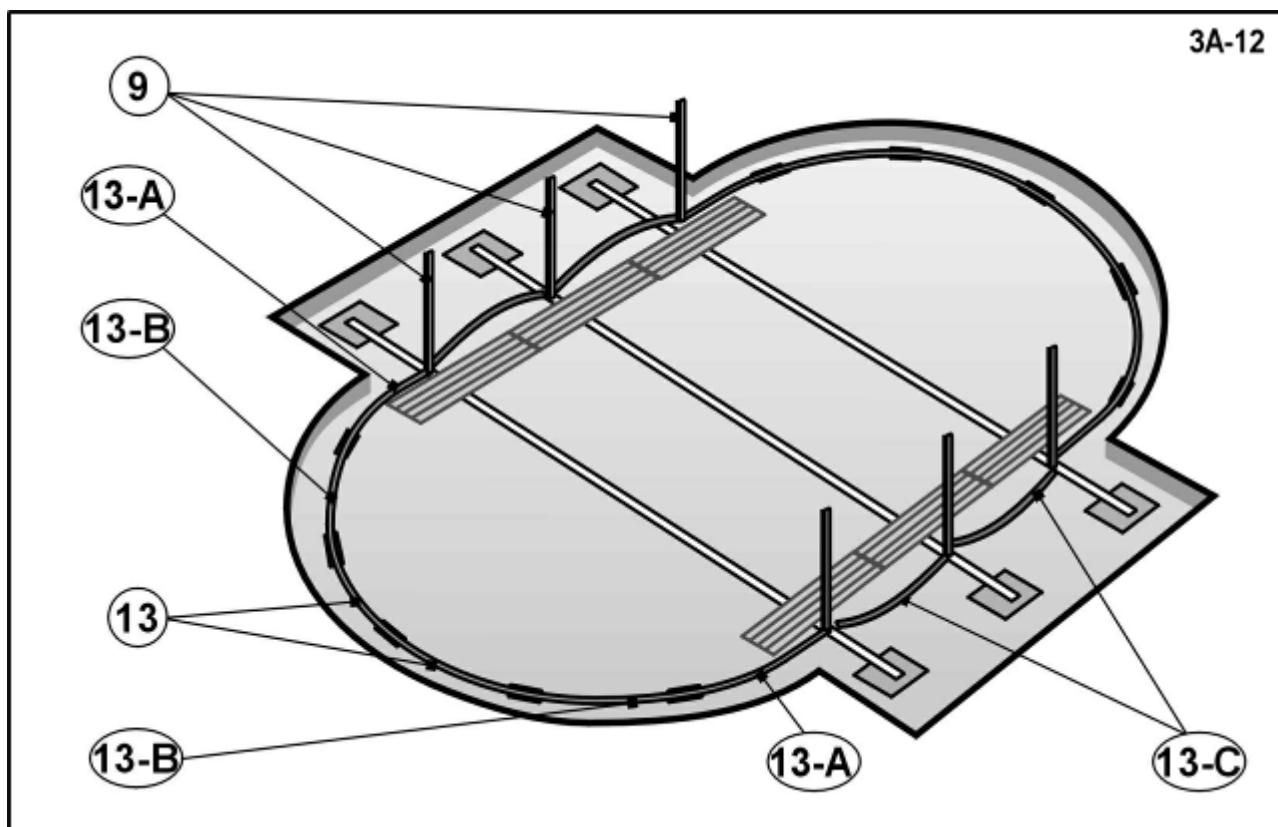

Note: All types of rails are used only for the swimming pool 5.5 x 10 m.

## 5. INSTALL LOWER RAILS OF TYPE "C"

- a. Some pools are equipped with a reinforcement brace (Fig. 3A-13). If this is the case, slide the reinforcement into the centre of the C type rail (Fig. 3A-14).
- b. Insert the rounded rail of Type C (Fig. 3A-15) between the adjacent vertical supports. Install it exactly as illustrated in Fig. 3A-20, i.e. with the groove upwards and inward into the pool, while the upper edge is facing into the cutting of the vertical support.

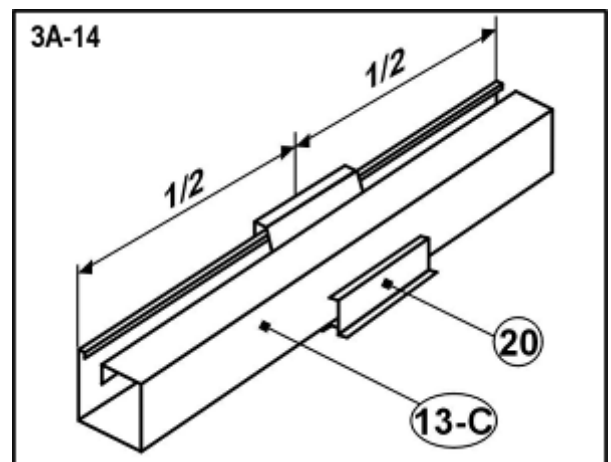
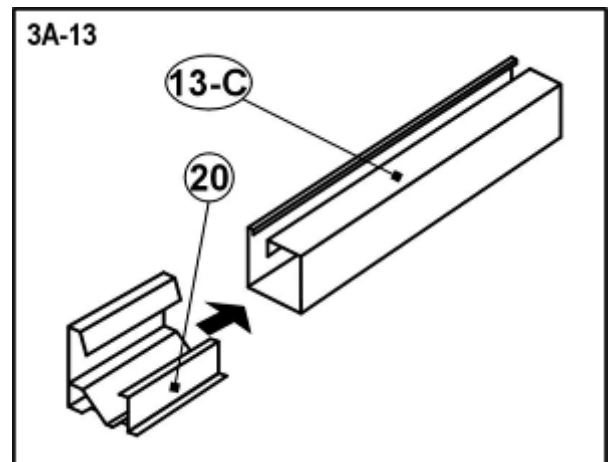

## 6. ADJUST THE DISTANCE BETWEEN VERTICAL SUPPORTS AND THEIR POSITION

- a. In the case of a pool with multiple strapping belts, please tie the string between the setting-out pins [D] and [E], [F] and [G].
- b. Now use the setting-out pins to align the strapping belts in such a way that they lie perpendicular to the pool axis and the vertical support, so that they are at the same distance from the axis.

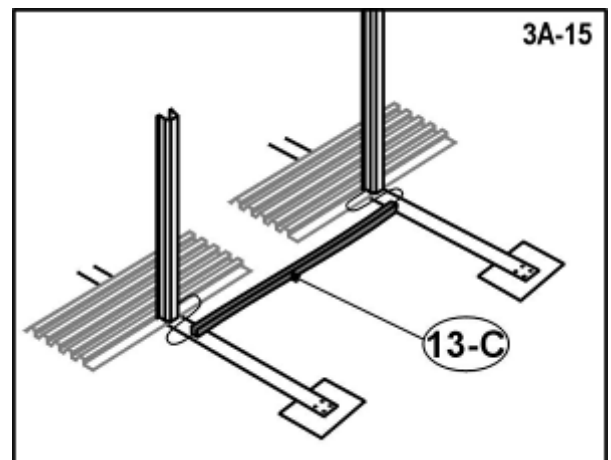

## 7. ADJUST THE UNDER BASE METAL SHEET

- Make sure that the base metal sheet lies fully horizontal. If this is not the case, level the base.
- Stand on the base metal sheet and fill the open holes of the base metal sheet with sand, sandy soil or similar materials (Fig. 3A-16). This will prevent low areas occurring around the base metal sheet after the pool is filled with water.
- Repeat the steps a. to b. for all base metal sheet.

**Recommendation:** After filling the open holes along the sides of the base metal sheets, we recommend putting a piece of stiff plastic sheeting (about 40 x 40 cm) over these holes. This will prevent other materials from entering the area under the base metal sheets through the holes and will prevent low areas occurring here as well.

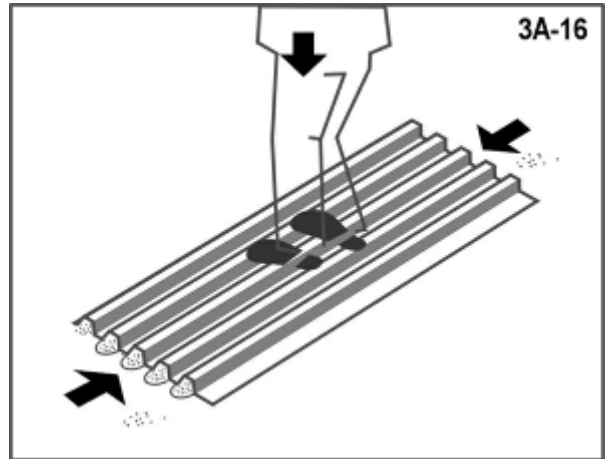

## 8. INSTALL TRANSITION RAILS OF TYPE "A"

- Install Type "A" rails into the external notch of the end vertical supports (Fig. 3A-17, 3A-18, 3A-19 and 3A-20), as illustrated in Figure 3A-20, i.e. with the groove facing upwards and inwards towards the pool and with their upper edge into the notch of the vertical support.

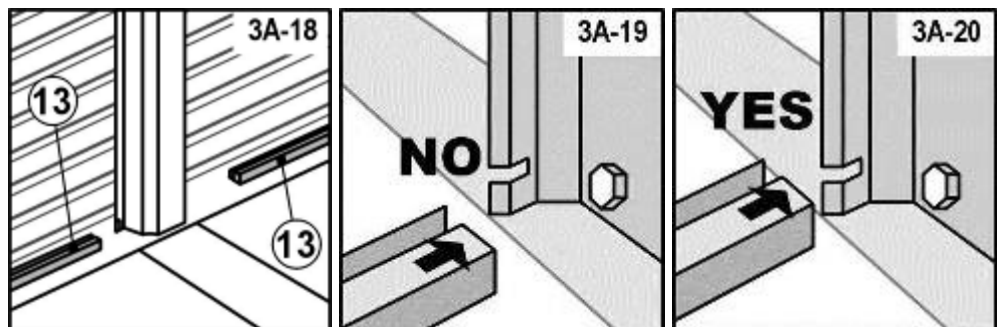
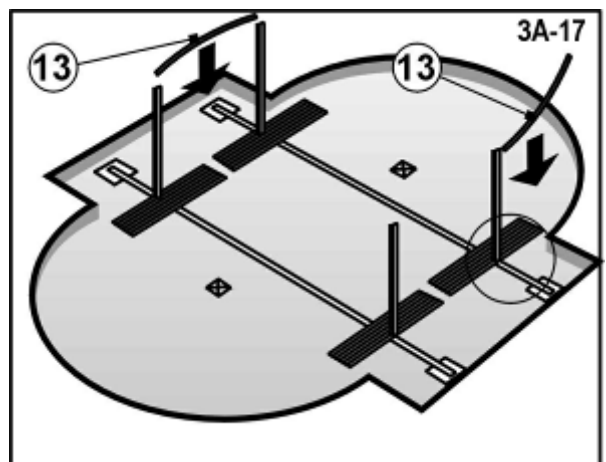

## 9. LAY THE BASE PLATES AND LOWER RAILS ON SEMI-CIRCLE ENDS OF THE POOL

- Install the connecting piece [2] (Fig. 3A-21, 3A-22 and 3A-23) onto the opposite ends of the Type "A" rail [13].
- Gradually install the remaining lower rails and connecting pieces. Leave a clearance of 55 mm (Fig. 3A-24) between the ends of the rails inserted into the connecting pieces.
- Create a semi-circle this way in both ends of the pool (Fig. 3-25).
- Use the string to ensure that the connecting pieces are situated at the right distance from the stakes [A] and [B].

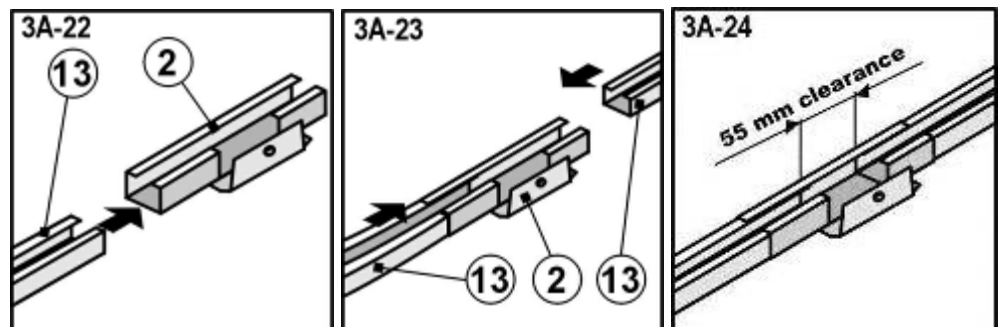
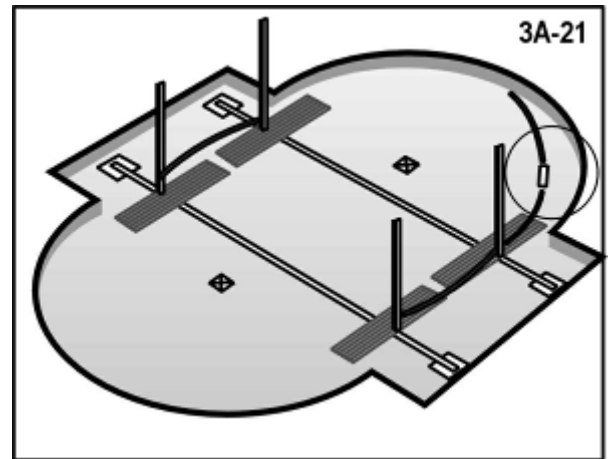

## 10. SPREAD FINE SAND

- Spread a layer of **not more than 2 cm of fine sand** (washed or sharp sand, if possible) all over the surface of the pool base, in order to level the internal surface of the pool and cover the base metal sheets (Fig. 3A-25). **Do not put sand near the lower rails**, as it could get into the groove of the rail. Leave an area (width about 10-15 cm) around the lower rails without sand. Use a rake to ensure that the layer is flat and smooth. The area may be sloped towards the centre of the pool.

**Note: A deeper layer of sand could adversely affect the future stability of the pool.**

- Put about 1.0 – 2.0 m<sup>3</sup> of sieved pit sand into the pool base, depending on the pool size. You will need this to create a corner filling (see Part 4, point 6, Shaping corner filling).

**Note: While handling the sand, be careful not to damage the lower frame or fill it with sand.**

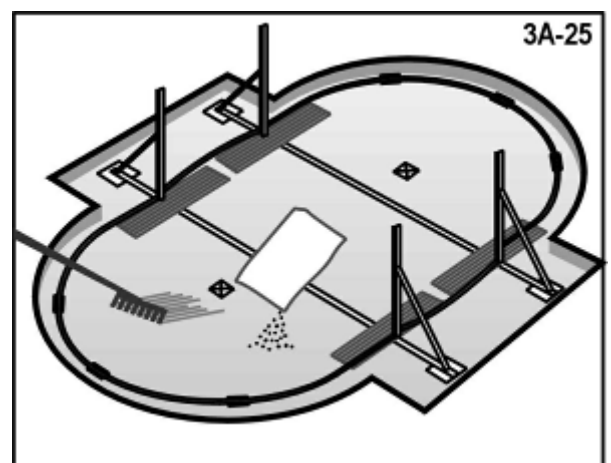

## 11. REMOVE THE SETTING-OUT PINS

- Remove all setting-out pins

## 12. PROCEED WITH PART 4 OF THE INSTRUCTIONS

# PART 3B

## ASSEMBLING THE BASE OF A ROUND POOL

### 1. LAY THE BASE PLATES AND LOWER RAILS ALONG THE CIRCUMFERENCE OF THE POOL

- Connect the curved lower rails [13] with the help of connecting pieces [2] and create the round lower frame of the pool this way (Fig. 3B-1, 3B-2 and 3B-3).
- Leave a clearance of 55 mm (Fig. 3B-4) between the ends of the rails inserted in the base plate.

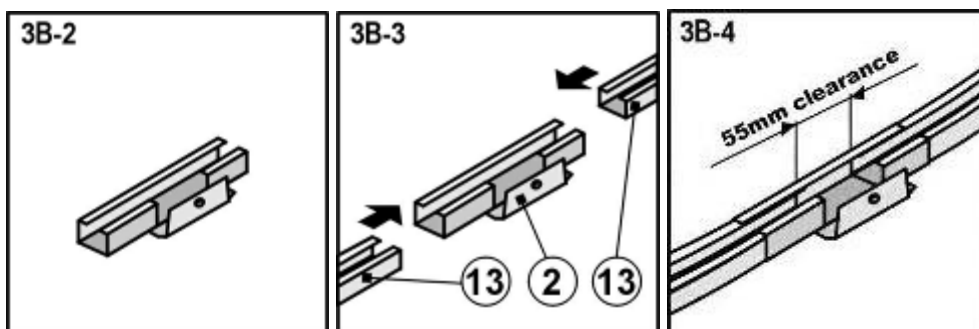
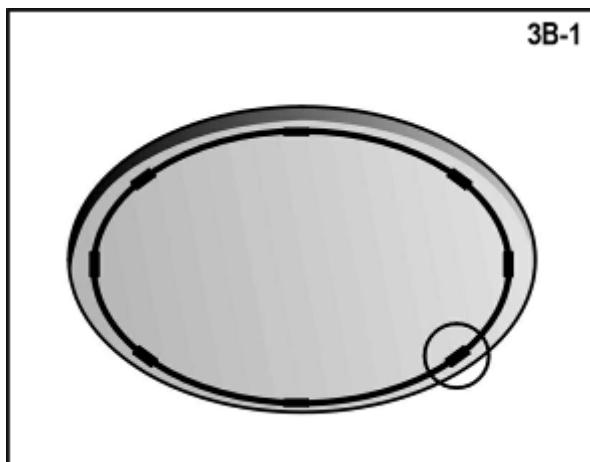

### 2. SPREAD FINE SAND

- Spread a layer of **not more than 2 cm of fine sand** (washed or sharp sand, if possible) all over the surface of the pool base, in order to level the internal surface of the pool and cover the base metal sheet (Fig. 3B-5). **Do not put sand near the lower rails**, as it could get into the groove of the rail. Leave an area (width about 15 cm) around the lower rails without sand. Use a rake to ensure that the layer is flat and smooth.

**Note: A deeper layer of sand could adversely affect the future stability of the pool.**

- Put about 0.3 – 0.6 m<sup>3</sup> of sieved pit sand into the pool area, depending on the pool size. You will need this to create a corner filling (see Part 4, point 6, Shaping Corner Filling).

**Note:** While handling the sand, be careful not to damage the lower frame or fill it with sand.

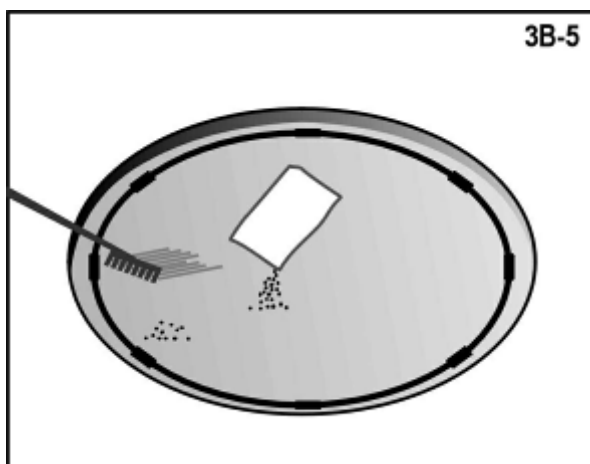

### 3. PROCEED WITH PART 4 OF THE INSTRUCTIONS

# PART 4

## ASSEMBLING THE POOL WALL AND LINER

### 1. ASSEMBLE THE POOL WALL

- a. Ideally, choose a sunny day for assembly. Do not attempt to assemble the pool when it is windy. You will require the assistance of at least one adult.
- b. Unwind the pool wall and place it in the middle of the pool base on a piece of plywood (Fig. 4-1). Make sure that the pre-punched holes for the skimmer are situated at the top part of the wall.
- c. In the case of an oval pool, please unwind the pool and split the rails [14] as per point 2 overleaf.

**Important:** Before unwinding the wall, make sure you locate the holes for the skimmer. They should be at the beginning of the wall, as illustrated in Figure 4-2. If this is not the case, the wall has been wound in the opposite way during production. If so, unwind the wall in the opposite direction to the one shown in Figure 4-2, i.e. in a clockwise direction.

- d. Start to unwind the wall and at the same time insert its lower edge into the curved lower rail. The beginning of the wall **must** be situated above one **connecting piece** [2] (Fig. 4-2 and 4-3) and the holes for the skimmer and return fitting must be situated at the place where the filter equipment is to be situated.

**Important:** In the case of an oval pool, the beginning of the wall must not be situated at the side support, but in one of the connecting pieces in the semi-circle edges of the pool.

- e. Unwind the wall and install the rails from the upper part [14] (Fig. 4-4). Leave a clearance of approximately 1 cm between individual rails

**Note:** In the case of an oval pool, install the rails according to the table in point 2 and Fig. 4-5.

- f. Continue around the entire base until the entire wall is constructed, inserted into the lower rails and fitted with the upper rails.

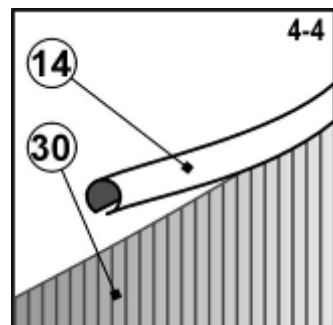
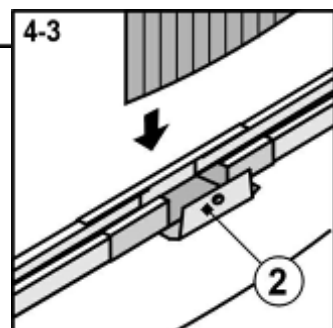
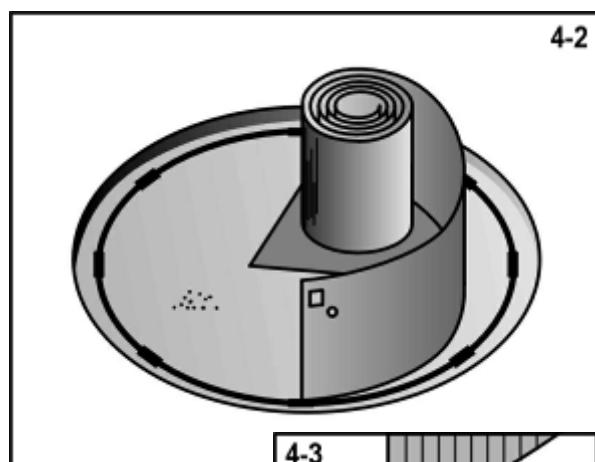
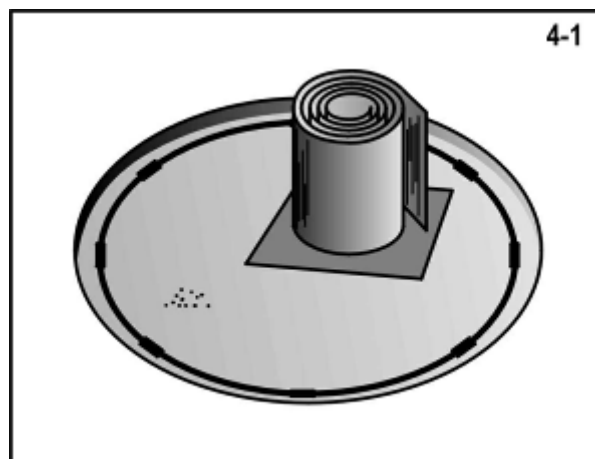

## 2. IDENTIFYING THE UPPER RAILS OF THE OVAL POOL

Every type of oval pool includes different rails [14]. These are rails of A, B and C type and end rails. To make identification easier, these rails are marked with colours and are assigned a part number. The rails and quantities can be identified using the table below and Fig. 4-5.

Pool size	Type C	Type A	Type B	End Rail
3.7 x 5.5 m (12' x 18')	none	4 – blue (1470127)	none	6 – colourless (1470126)
3.7 x 7.3 m (12' x 24')	4 – white (1470105)	4 – black (1470129)	none	6 – colourless (1470126)
4.6 x 7.3 m (15' x 24')	2 – white (1470105)	4 – green (1470100)	none	8 – colourless (1470097)
4.6 x 9.1 m (15' x 30')	4 – green (1470100)	4 – green (1470100)	none	8 – colourless (1470097)
5.5 x 10.0 m (18' x 33')	4 – green (1470100)	4 – green (1470100)	4 – green (1470100)	6 – colourless (1470098)

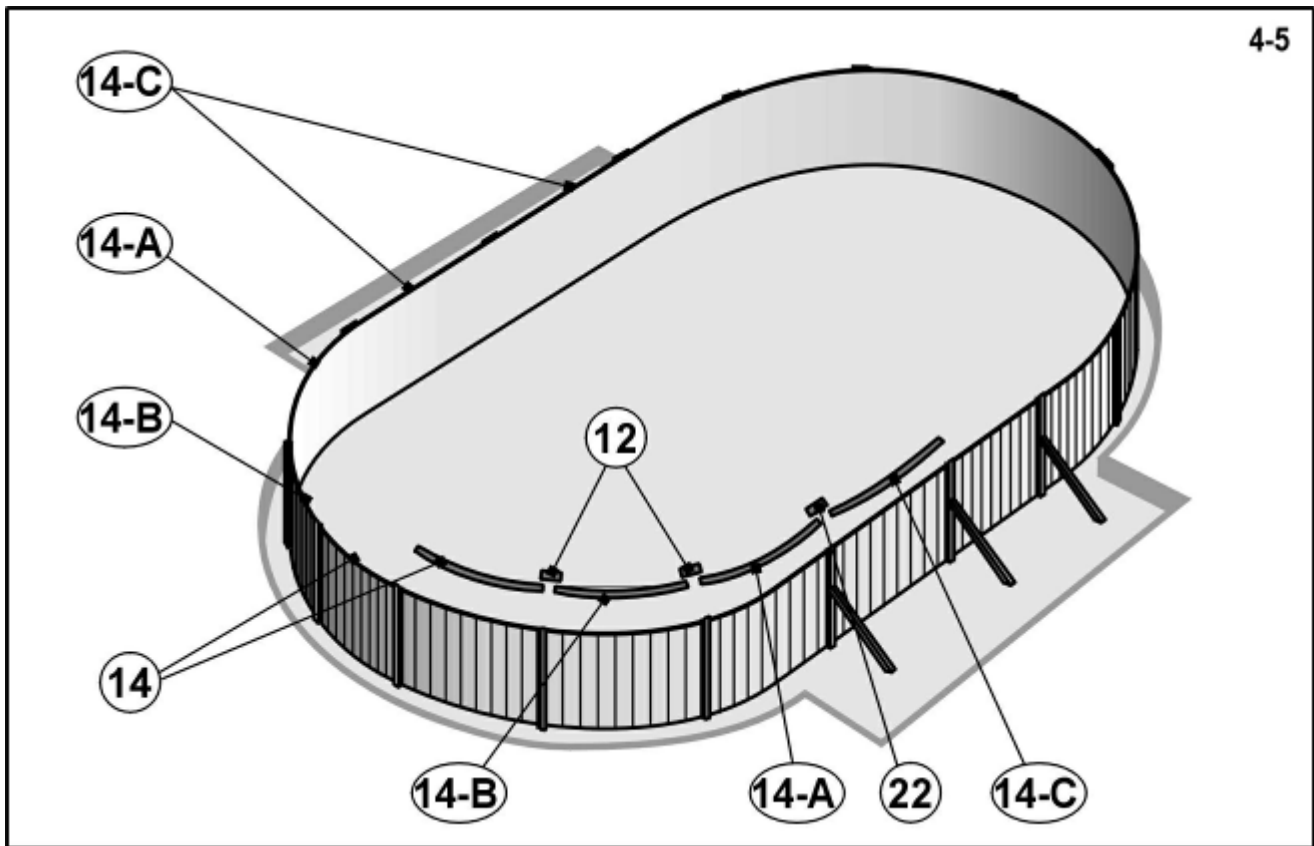

## 3. CONNECTION OF UPPER RAILS

- Connect the rails [14] on the upper edge of the pool wall using the rail couplings [12] (Fig. 4-5).
- In the places where there are vertical supports with an inclined support (in the case of an oval pool), leave a clearance of about 10 cm between the rails [14], and connect the rails [14] using a plastic insert [22] (Fig. 4-6).

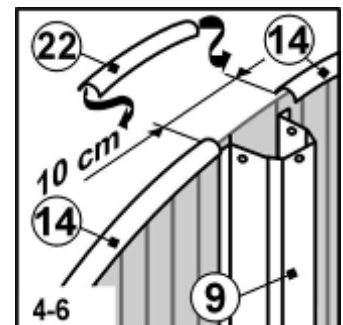

**Hint:** Attach the top of each vertical support [9] to the wall with the help of adhesive tape. By doing so, you can temporarily secure the wall against collapse prior to attaching it to the vertical supports.

**Hint:** Attach each rail coupling [12] to the wall with the help of adhesive tape. This prevents the rails from sliding away from the wall when installing the liner.

#### 4. CONNECT THE POOL WALL ENDS

- a. Align the holes in the two ends of the pool wall with each other (Fig. 4-7).

**Hint:** Putting a screwdriver through two opposite holes will facilitate alignment.

- b. In order that the holes are aligned with each other, make a circle which is formed by the pool wall. The circle should be larger or smaller; make it in such a way that you are pushing the base plates with your foot outwards or inwards to the circle centre.

- c. Connect the ends of the pool wall – insert a bolt **from inside** the pool into each aligned set of holes, and screw on the nut. The bolt heads should be **inside** the pool and all the nuts should be on the **outside** of the pool (Fig. 4-8).

- d. First hand tighten the connections. When all the connections are made, tighten them using the appropriate tools.

- e. Cover the wall end coverings and bolt heads on the inner side of the pool wall by using an adhesive tape (Fig. 4-9), if possible textile adhesive tape.

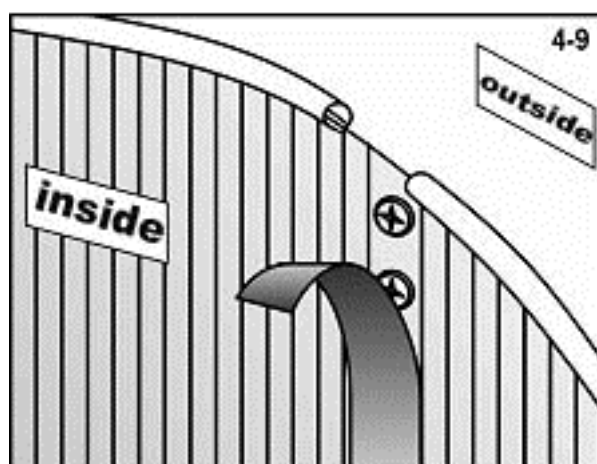
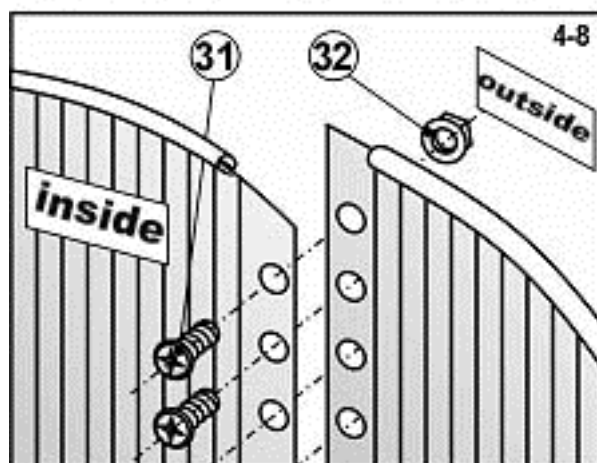
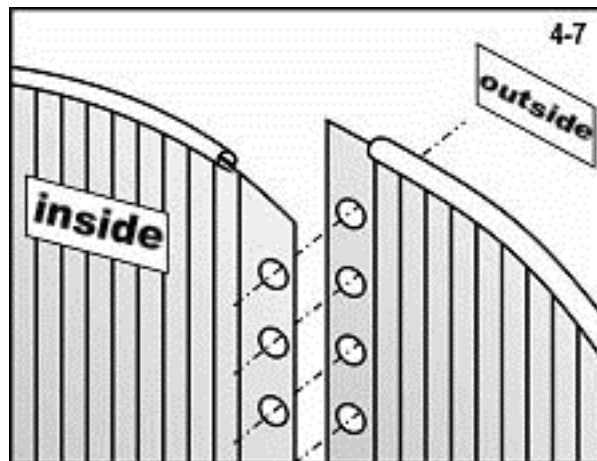

**Hint:** We recommend using the assembled pool step ladder for entering and leaving the pool.

## 5. CHECK WHETHER THE POOL WALL IS LEVEL

- a. Use tight string with a suspended spirit level (Fig. 4-10) to check whether the opposite upper edges of the pool wall are level. Check the wall in several different directions. The wall must stand on a horizontal plane. If it deviates by more than 25 mm (Fig. 4-11), then put the wall aside and level the pool base again.

**Warning: A pool which is not level is dangerous and may collapse.**

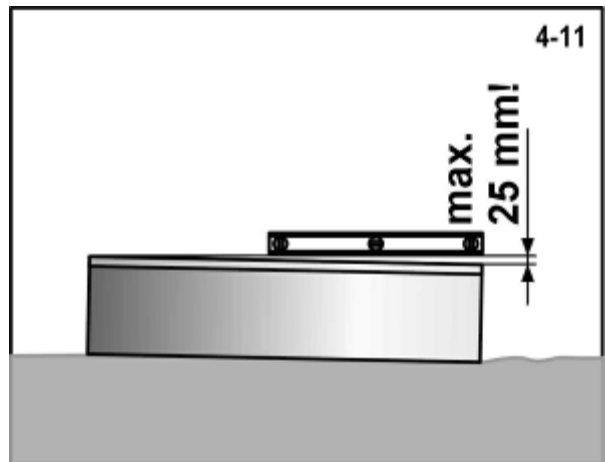
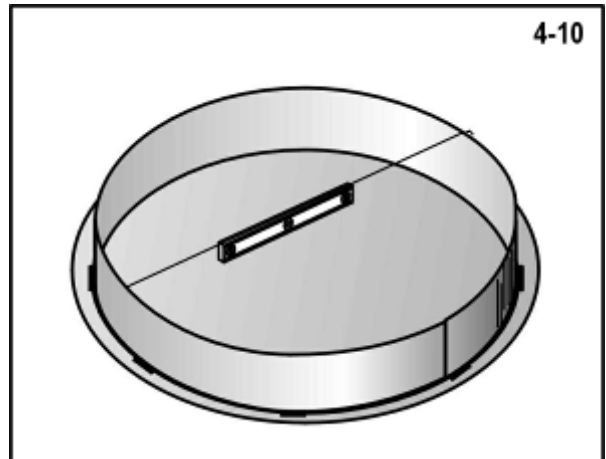

## 6. SHAPING CORNER FILLING

- a. Using sieved pit sand, shape a rounded corner filling which is about 20 cm wide and 20 cm high, at the bottom part of the wall, along the entire circumference inside the pool. Shape the rounded corner and firmly compact it (Fig. 4-12).

**Important:** In the case of an oval pool, at the point where there is a vertical support with an inclined support, it is necessary to adjust the size of the corner filling according to the data stated in Fig. 4-13. At the same time, it is also necessary to ensure that the surface of the base metal sheet is covered with a layer of compacted sand approximately 2 cm thick. The base metal sheet profiles must not stick out of the bottom area.

- b. Now level the bottom surface using the rake until it is smooth.
- c. Place a felt pad on the pool bottom to protect the pool liner from damage. See Annex A for Instructions for Use.
- d.

**Note:** The felt pad for the pool is not included in the pool package. Please contact your dealer for details.

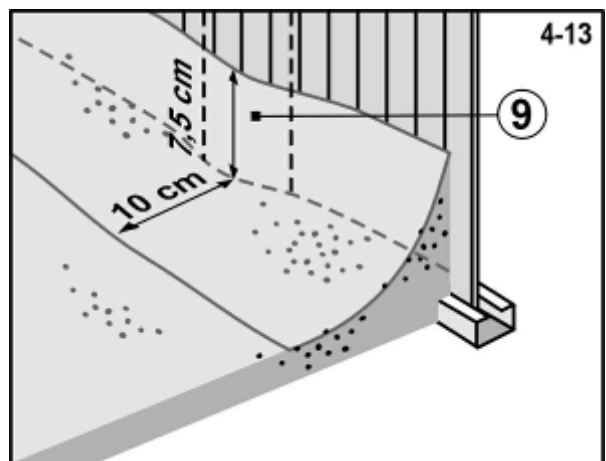
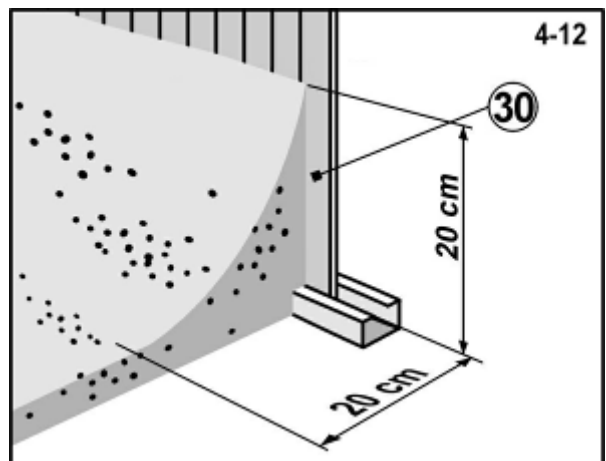

## 7. INSTALLING THE LINER

**Note:** If you intend to use a filter with the pool, it will be necessary, part of the skimmer installation will need to be done prior to installing the liner. In this case, consult the appropriate Instructions for Skimmer Installation for proceed accordingly. See Annex B for the Instructions.

- Open the cardboard box. **Do not use** any sharp tools to open the box.
- Unwrap and unwind the liner, preferably in the sun, so that it can become warm. Check the entire surface of the liner and all seams to ensure that they are not broken.
- Spread the liner in the pool in such a way that it the face part of the seams faces upwards. The arc-shaped seam should be situated in the middle of the apex of the corner. The other seams will form lines across the pool base (Fig. 4-14 and 4-15).
- Smooth any wrinkles in the liner on the pool base.

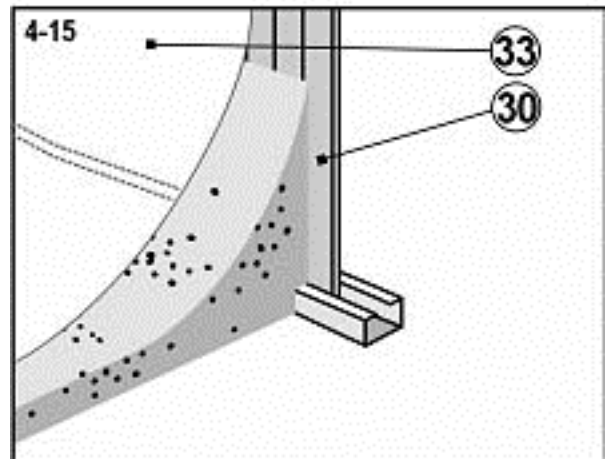
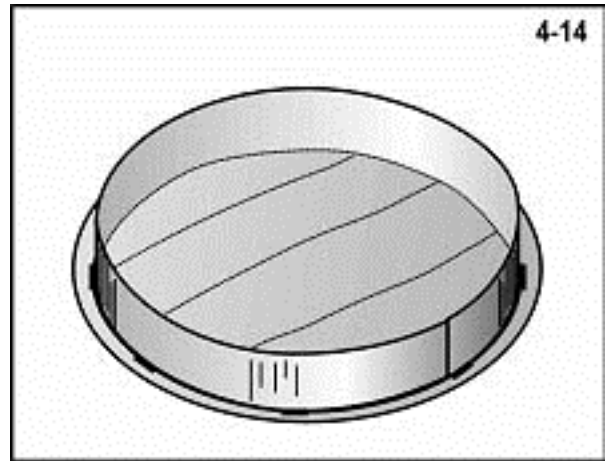

## 8. ATTACHING THE LINER

- Pull the liner over the edge of the pool wall and attach it temporarily with the help of several plastic clamping bars (Fig. 4-16). Leave the liner hanging freely for the time being. **Do not pull** the liner too much.
- Start to fill the pool with water. While the pool is being filled, smooth out any wrinkles in the liner in a circular movement from the pool centre towards the wall. You can use a soft brush. Never press on the liner with excessive force and do not pull it out. Proceed quickly, because a few centimetres of water can press the liner towards the base in such a way that it will not be possible to move it without damaging it. While working, be sure to keep the arc-shaped seam in the middle of the corner filling (see Fig. 4-15).
- After smoothing the bottom, continue to fill the pool and gradually smooth the liner on the wall. Be sure to avoid straining the liner and creating an air gap (see Fig. 4-17).

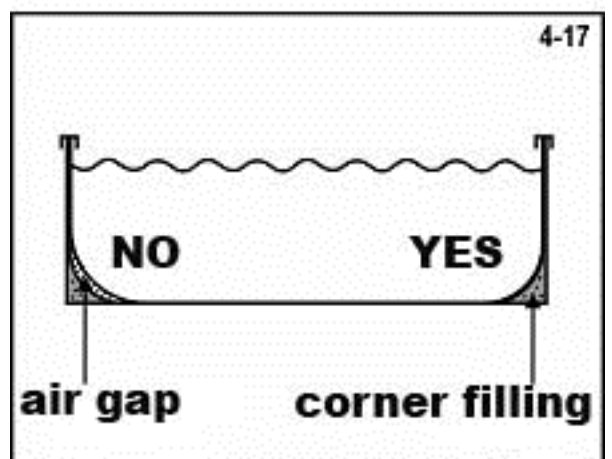
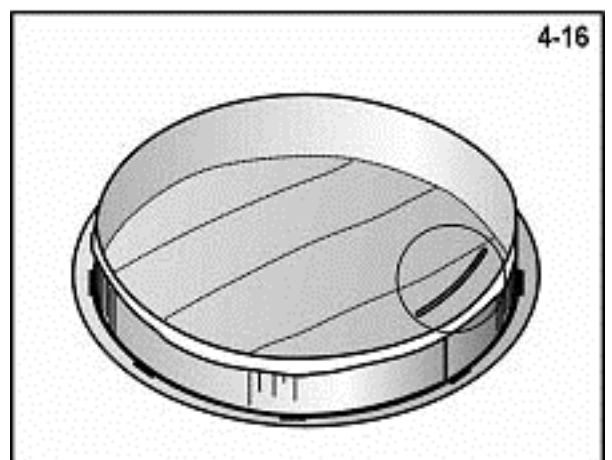

- d. Gradually remove the plastic clamping bars on the upper edge of the wall, **always one piece at a time** and smooth any wrinkles on the liner. Install the plastic clamping bars on the smoothed part immediately one after another (Fig. 4-18).
- e. After having smoothed all wrinkles on the liner, cut away the protruding part of the last plastic bar so that its end sits close to the adjacent bar (Fig. 4-19).

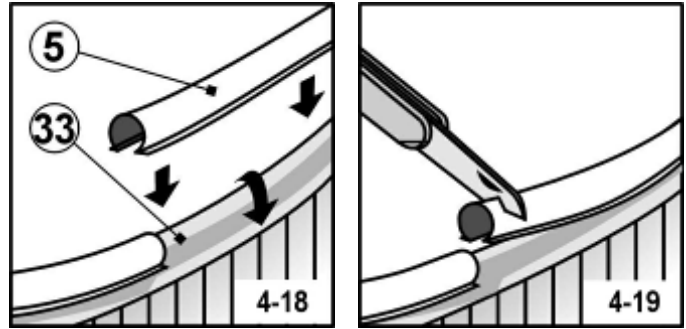

**Note:** It is normal for there to be slight waves on the liner during installation. This is caused by movement of the vinyl material used to protect the liner during packing.

**Note:** The liner is not a structural part of the pool. Its main function is to prevent water from flowing out of the pool. Water pressure is maintained by the walls and structural elements of the pool. The liner must fit properly to the ground, corner filling and pool wall; it must never bear the weight of the water, as this could damage it.

## 9. PROCEED WITH PART 5 OF THE INSTRUCTIONS

# PART 5

## INSTALLING THE TOP RAILS AND VERTICAL SUPPORTS

### 1. IDENTIFYING UPPER RAILS

Every type of oval pool has different upper rails [6]. These are rails of Type A, B and C and end rails. To make identification easier, these rails are marked with colours and are assigned a part number. The rails and quantities can be identified using the table below and Fig. 5-1.

Pool Size	Type C	Type A	Type B	End Rail
3.7 x 5.5 m (12' x 18')	none	4 – blue (1450601)	none	6 – colourless (1450182)
3.7 x 7.3 m (12' x 24')	4 – white (1450600)	4 – black (1450602)	none	6 – colourless (1450182)
4.6 x 7.3 m (15' x 24')	2 – white (1450600)	4 – red (1450603)	none	8 – colourless (1450437)
4.6 x 9.1 m (15' x 30')	4 – green (1450605)	4 – red (1450603)	none	8 – colourless (1450437)
5.5 x 10.0 m (18' x 33')	4 – green (1450605)	4 – red (1450603)	4 – yellow (1450185)	6 – colourless (1450184)

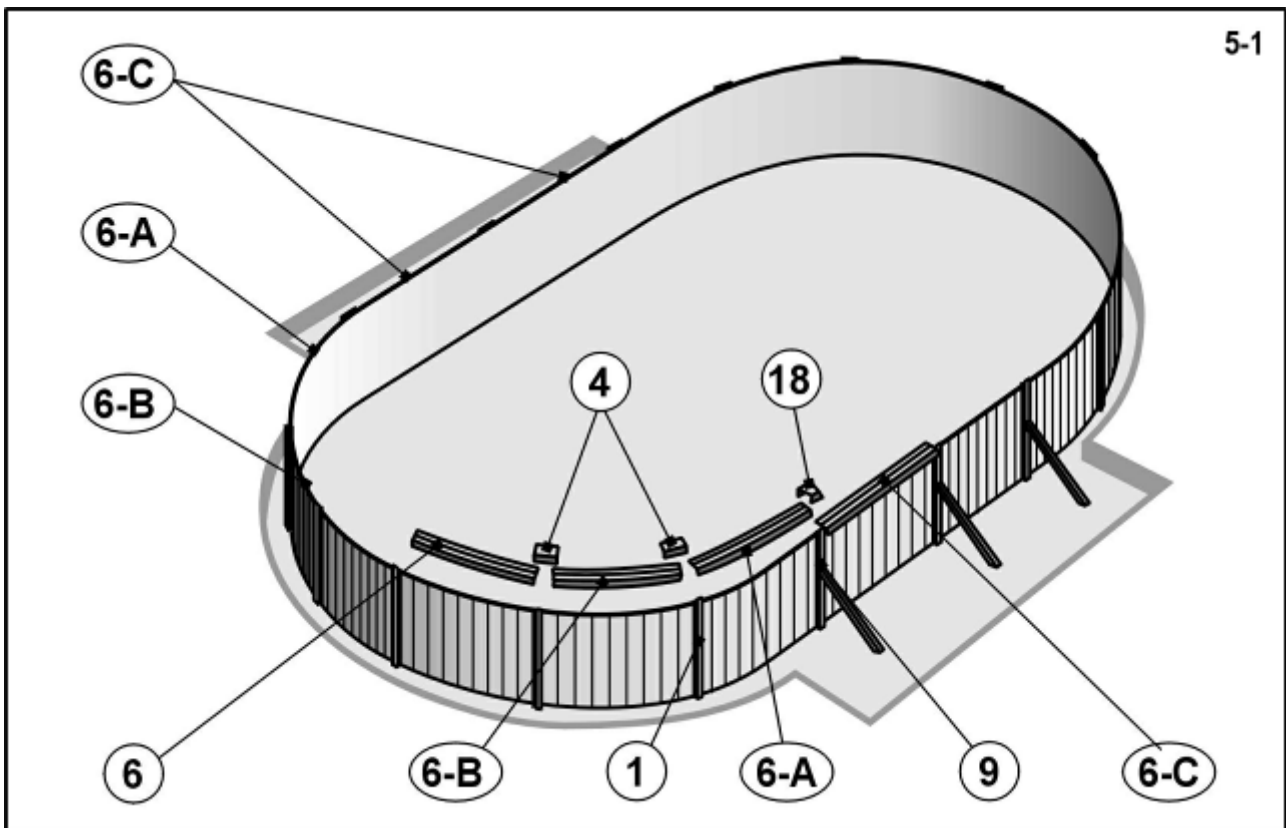

### 2. CONTINUE TO FILL THE POOL

- a. Continue to fill your pool with water and, whilst doing so, install the upper frame and the pool vertical supports.

### 3. INSTALL THE VERTICAL SUPPORTS AND UPPER RAILS

**Note:** In the case of a round pool, skip points a. and b. and proceed As per points c. to h.

- a. Install the metal plate [17] to the upper end of the vertical support with an inclined support [9] (**oval pool only**) and to the wall [30]. Align the holes in the plate and vertical support and screw the two parts together using self-tapping screws [3] (Fig. 5-2).

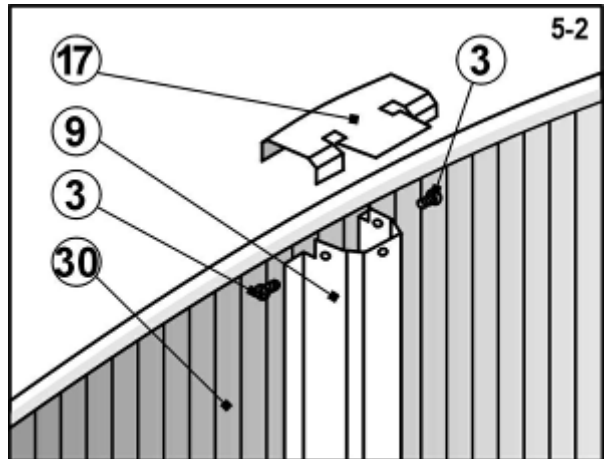

- b. Slide the upper rails (Fig. 3) from both sides onto the metal plate [17], depending on the type of **oval pool** (Fig. 5-3).

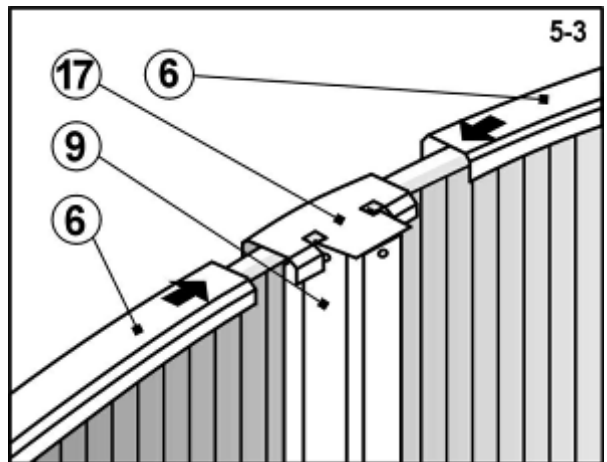

- c. Attach and align the bottom part of one vertical support [1] in the round part of the pool with the clip of one connecting piece [2] (Fig. 5-4). The flap of the clip of the connecting piece must be situated **outside** the vertical support.

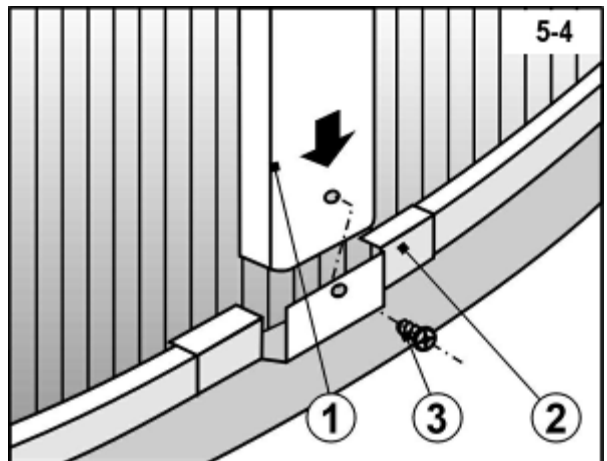

- d. Align the hole for the screw in the vertical support with the hole for the screw in the flap and attach the vertical support with a self-tapping screw [3] (Fig. 5-4).

- e. Place the upper coupling [4] onto the upper edge of the pool wall, so that the flap of the slip of the upper coupling is situated outside the pool (Fig. 5-5).

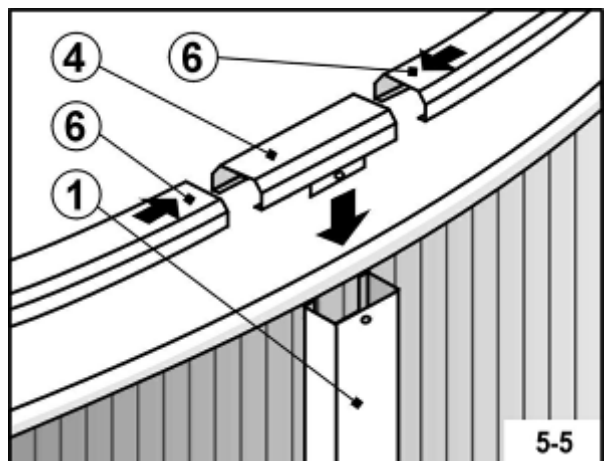

- f. Slide one end of the upper rail [6] into the upper coupling [4]. Align the hole for the screw in the flap with the hole for the screw in the top part of the vertical support [1]. The flap of the clip of the upper coupling must be **outside** the vertical support. The vertical support must be in a vertical position.

g. Attach the upper coupling to the vertical support with one self-tapping screw [3]. It is necessary to put heavy pressure on the vertical support (Fig. 5-6).

h. Repeat the steps for each vertical support along the circumference of the pool wall.

**Hint:** Use the grooving on the pool wall to check the columns are vertical.

i. In the case of an oval pool, install the plastic decorative cap [18] onto the metal plates [17]. Install the cap following the procedure illustrated in Fig. 5-7. Secure the cap using the screw [19] (Fig. 5-8).

**Note:** The self-tapping screws [19] are 25 mm long and differ from other self-tapping screws provided with the pack. Only these screws should be used for attaching the cap.

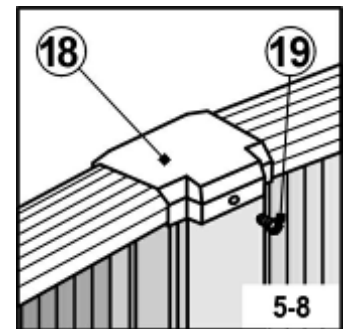
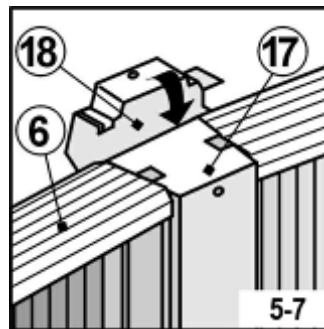
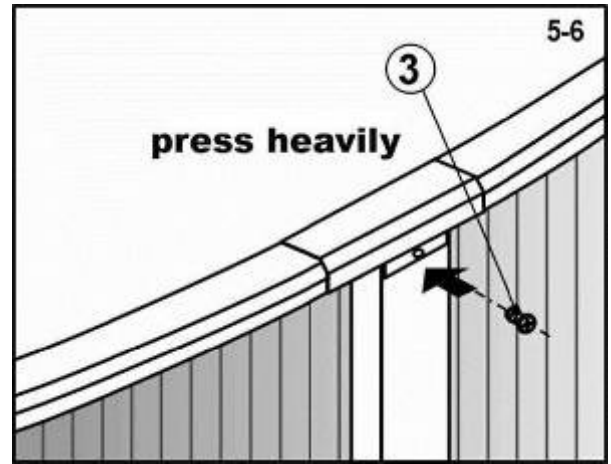

#### 4. APPLY THE WARNING LABEL

a. Apply the warning label near to the point used for entering or leaving the pool.  
NB: The pool is not deep enough to jump into safely; any attempt to do so could result in injury.



#### 5. FINISH FILLING OF THE POOL

a. Fill the pool with water to 5 cm below the lowest hole in the pool wall. Then proceed according to the Assembly Instructions for your skimmer.

**Important:** The pool might buckle or shift while being filled with water. This is normal.

b. Attach the filter equipment to the skimmer installed, as per the appropriate Instructions.

c. Fill water up to the level of the centre of the inflow front plate of the skimmer and carry out primary disinfection of water (see Annex C). Your pool is now ready for use.

**Warning:** Anyone using the pool should read the Safety Instructions beforehand and observe them. The Safety Instructions are included in Part 6.

# PART 6

## SAFETY INSTRUCTIONS

Your pool contains a large quantity of water and is deep enough to potentially endanger life and health unless the following safety rules are strictly observed. First-time users are most at risk of injury. Make sure everyone understands all safety rules before entering the pool.

### 1. No Jumping or Diving



The top rail of your pool is not a walkway and must not be used for jumping or diving. **Do not permit** jumping or diving into the pool from a deck or the top rail of the pool. Diving or jumping into the pool can result in serious injury or even death by drowning.



### 2. Never use the Pool Alone

**Never permit** the pool to be used unless it is attended by at least one person other than the bather. Someone should always be available to lend assistance in an emergency.



### 3. Never Leave Children Unattended

**Never leave** a child alone and unsupervised in or near the pool—not even for a second. There is no substitute for constant adult supervision.



### 4. No “Horseplay”

**Do not permit** “horseplay” in and around your pool. Surfaces can become slippery and hazardous when wet.



### 5. Light the Pool at Night

If the pool is used after dusk, adequate lighting must be provided. Illumination in the pool area must be sufficient to clearly judge pool depth and all features in and around the pool. For lighting recommendations, consult your local licensed electrical contractor.



### 6. Restrict Access to the Pool

**Do not leave** chairs or other furniture beside the pool that could be used by a child to climb up into the pool. **Ladders must be removed** whenever the pool is unattended. A fence with a lockable gate around the pool or yard is strongly recommended and may be required by law in some countries.



### 7. No Alcohol or Drugs

The use of alcohol or drugs **does not mix** with pool activities. Persons who have been drinking alcohol or using any drugs should not be allowed in the pool, and should be carefully supervised in the surrounding area.



### 8. Keep Your Pool Clean and Sanitary

The pool water must be regularly filtered and chemically treated so that it remains harmless to health. Use a suitable filter system to remove suspended particles from the water and suitable preparations of pool chemicals according to their instructions in order to destroy harmful bacteria and eliminate algae formation. Remember, unsanitary water is a serious health hazard.

**Warning: Do not modify the pool and do not interfere with the structure of the pool once it is assembled and filled with water. It could result in the pool collapsing or in serious injury.**

# PART 7

## USING THE POOL

---

When using your pool, please comply with the following instructions to maintain the pool in a clean and good condition.

### 1. USING THE POOL

- a. Before entering the pool, take a shower and ensure you clean your feet.
- b. Do not enter the pool with your shoes on, as this could result in damage to the liner.
- c. Always use the ladder when exiting the pool. Exiting the pool incorrectly could result in damage to the internal liner.
- d. Maintain the water level at the height prescribed, approximately level with the centre of the skimmer front plate. Remember that water evaporates from the pool under every weather condition, and it is therefore necessary to replenish the pool with water. Common evaporation is normal and it should not be confused with water loss due to leakage.
- e. Check the pool and its accessories regularly to ensure that water does not leak. Repair any possible leakage by retightening or resealing the connection in question.

### 2. TAKING CARE OF POOL WATER

- a. It is extremely important to take correct care of the pool water to keep the pool in an appropriate sanitary condition.
- b. The pool water temperature should not exceed 30 °C. An optimum water temperature is about 25°C. Hot water is not refreshing and, more importantly, it reduces the efficiency of the sanitation substance (chlorine) and produces optimum conditions for algae formation. A high water temperature also causes softening of the pool liner and the risk of wrinkling to the liner. If the pool water temperature reaches 30 °C, do not use water heating, remove the cover and, if possible, replace part of the water volume with colder water.
- c. The principles of pool operation and important instructions for the use of chemical preparations are shown in Annexe C.

**Warning: In the case of an embedded pool, water is not fully drained off. It is only necessary to reduce the water level below the level of the return fitting as part of the winterising measures, (see Part 9. Winterising). Complete draining of the water should only be performed for the minimum time possible and only in the event of repairs to the liner or if it is necessary to replace the liner. If in doubt, please contact your dealer.**

# PART 8 – POOL MAINTENANCE

---

## 1. LINER

- a. Check the liner regularly for leaks. A liner with holes may cause a drop in water level, which may result in damage to the pool or the filter unit.
- b. Minor repairs can be made to the liner with a repair kit. Any major damage should be resolved by replacing the old liner with a new one.

## 2. POOL WALL, VERTICAL SUPPORTS AND SUPPORTS

- a. Keep the pool wall, vertical columns and supports clean. Wash them down with mild soap. Do not use abrasives, chemical solvents or cleaning powders.
- b. Wash off any spilled pool chemicals right away.

**Warning: Concentrated chlorine may cause damage to the pool liner and metal parts of the pool. Wash down any contamination right away.**

- c. Recoat all exposed screw heads and nuts with clear outdoor varnish.
- d. Check regularly all metal parts for possible corrosion, at least once a season. All grooves and corroded areas on metal parts should be treated with a suitable anti-corrosion coating – follow the instructions provided on the can.

**Remember:** All corroded areas on the pool wall must be coated with an anticorrosion coating. If the pool is heavily corroded, it may collapse.

- e. Pay special attention to any leaks at the skimmer and return openings. Leaks must be fixed immediately.

## 3. POOL LADDERS

- a. For safety and practical reasons do not leave step ladders in the pool unnecessarily. Only fit them for the period of time which is absolutely necessary, ie: when the pool is in use.
- b. The pool ladders are exposed to the effects of chemicals dissolved in the water. It is therefore necessary to check them for corrosion from time to time. If you see symptoms of corrosion, treat the areas concerned with the appropriate coating.

# PART 9

## WINTERISING THE POOL

---

At the end of the swimming season, you must follow these directions to prepare your pool for winter. While doing so, it is necessary to continue regular care of the pool water, including the filter system, until the time of winterising.

**Note:** A well winterised pool makes the new season start up easier.

### 1. LOWER THE POOL WATER LEVEL

- a. First adjust the pH value and concentration of the sanitation substance in the pool water to the correct parameters.
- b. Clean any contamination from the bottom.
- c. Reduce water level in your pool to a level of about 10 cm below the return fitting.
- d. Use a suitable cleaning agent to remove the tide mark of the original water level from the pool wall before drying.
- e. Treat the remaining water by using a suitable preparation for winterising.

**Warning: Do not drain all the water from your pool for the winter, and do not remove the liner. An empty pool can collapse in the winter.**

Drain the water from your pool into grass on your own land. When draining water into a land surface water course, this must be discussed beforehand with the appropriate water management authority.

### 2. CHECK ALL JOINTS AND SCREWS

- a. Make sure all the frame joints are fitting together properly and make sure the pool wall has not shifted from the bottom rail.
- b. Make sure all screws and bolts are tight.

### 3. CHECK FOR RUST

- a. Paint any scratches or rusty areas with anti-rust paint.

### 4. CHECK THE LINER

- a. Make sure the top of the liner is still attached to the pool wall with plastic coping. Do not remove the liner from the pool. Removal of the liner will void the existing warranty.

### 5. FINDING LEAKS

- a. Make sure the liner has no leaks. Leaks in the winter can cause severe damage to your pool.

### 6. POOL ACCESSORIES

- a. Remove all pool accessories from the pool, including the ladder.
- b. While winterising the filter equipment, observe the winterising instructions.
- c. Leave the skimmer and return fitting installed on the pool wall.

### 7. COVERING THE POOL WITH A COVER SHEET

- a. If you have a cover sheet, install it on the pool. By doing so, you will protect the inner part of the pool from penetration of impurities (leaves, seeds, etc.) during winterising.

**Remember:** Incorrect winterising will make the pool warranty void and invalid. Adhere carefully to all the winterising instructions.

**Warning: Prevent children, farm animals and pets from accessing to the pool when it is winterised. Do not skate on a winterised pool and do not climb on to the ice! This could lead to liner damage or physical injury.**

# ANNEXES

## A) INSTRUCTIONS TO USE FOR FELT PAD

---

**Note:** The felt pad is not a part of the pool package. Please contact your dealer for details.

The unwoven textile “NETEX S” (material for felt pads) is made of 100% polypropylene staple fibres of a white colour. It is used as a filler, drainage and separation geo-textile during construction of roads and railways, dump areas, airports, storage and parking areas, etc. It is also used for protecting pool liners and separating them from the base.

### Felt Pad Characteristics

The fibres used for producing the pad are subject to aging in the light after a certain time (known as photo degradation). This is why it is unsuitable to store the felt pad freely. It should be stored in a cardboard box or in the foil which is stabilised from UV radiation.

The unwoven textile is resistant to technical petrol, perchloro-based substances, oil and other chemicals of a similar nature, to fungus growths and micro-organisms. It is not harmful to health.

### Laying the pad for the pool with a corner filling

Install the felt pad after you have assembled the pool wall and made the internal corner filling by using the sieved pit sand. Place the pad on the bottom inside the pool, centre it and align possible folding pieces. Cut away several centimetres above the corner filling.

While doing so, make sure that no stones or other sharp objects get to the upper side of the pad.

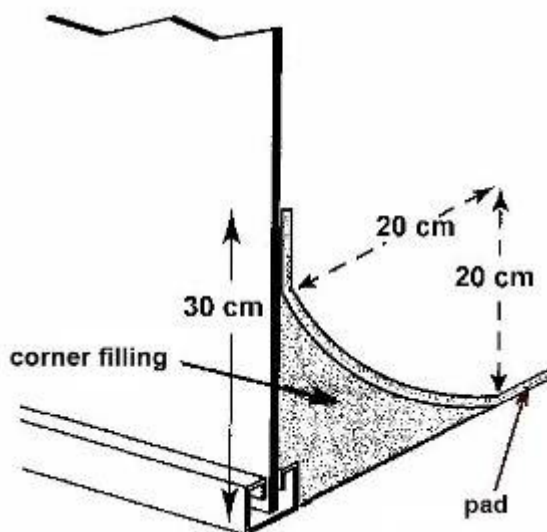

## B) INSTRUCTIONS FOR ASSEMBLY AND USE OF THE SKIMMER

**Note:** The level skimmer for removing impurities is not included in the pool delivery. Contact your dealer.

### 1. USE

The skimmer is used for suction of water from the pool level through a filter device. Insects, leaves and other floating impurities are drawn into the skimmer and caught in the basket. A reinforced hose (both 5/4" (32 mm) and 6/4" (38 mm)) can be connected to the skimmer.

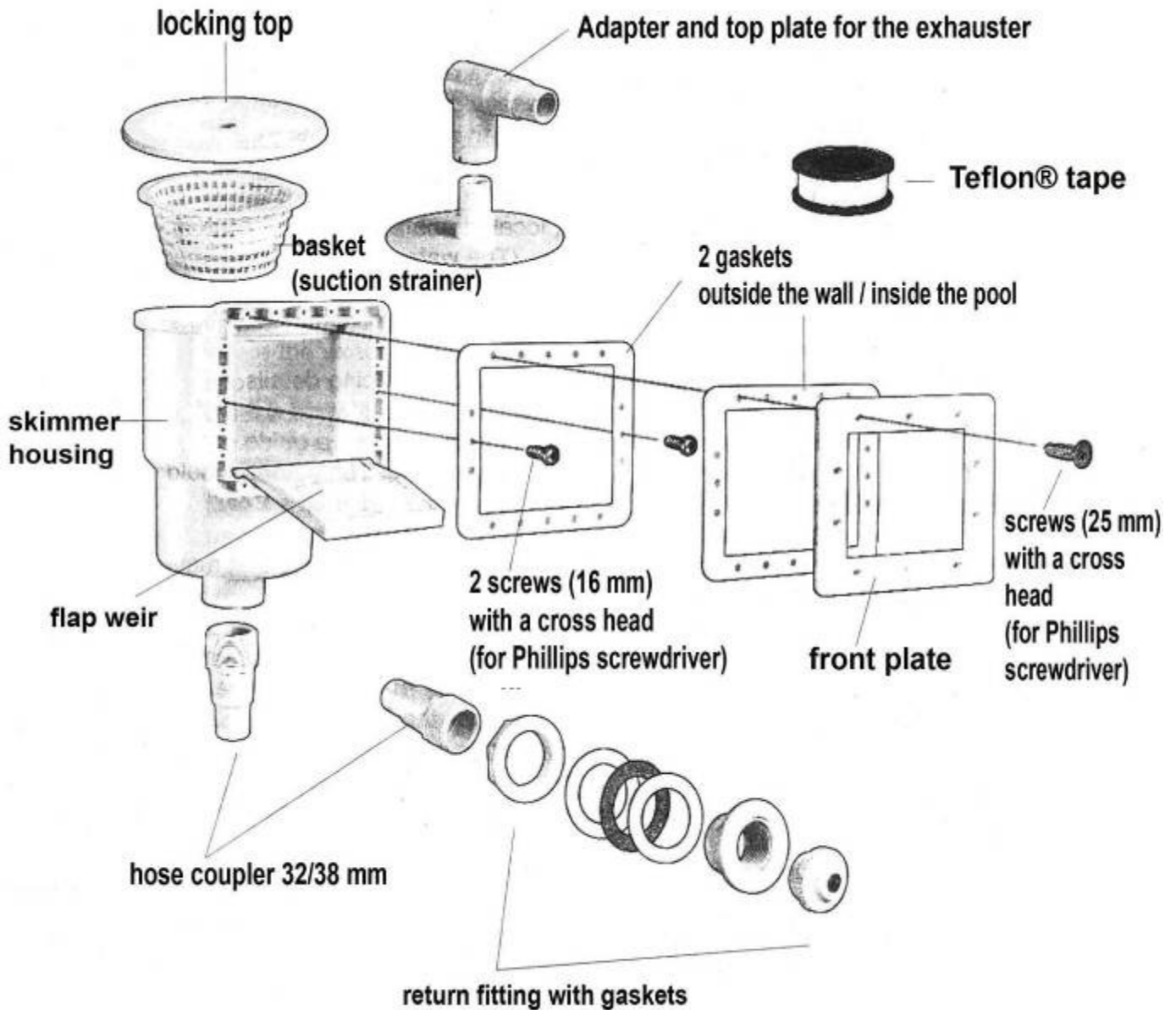

## 2. ASSEMBLY

### Assembly Instructions for the Skimmer for Above Ground Pools

Note: For assembly you will need a Phillips screw driver and a sharp-bladed knife.

- a. Before installing the liner in the pool, punch holes in the wall for screws and for the skimmer holes and return fitting. Smooth and grind the edges of the holes to remove any sharp edges. Install the gaskets supplied with the pool onto the skimmer hole.
- b. Take one hose coupler and screw it into the skimmer housing. Use Teflon® tape for sealing (do not use adhesives or sealing putties).
- c. Before commencing the actual installation, the skimmer housing should be already partially screwed to the pool wall. Place one gasket and the skimmer housing to the holes marked out from the external side of the pool. Secure the position by using a couple of shorter screws in central holes along the sides of the skimmer. Before doing so, check the flap valve is correctly installed in the entry front plate of the skimmer housing. The flap valve must move freely.
- d. Now install the pool liner and fill the pool with water so that the water level reaches to 5 cm below the lowest connection hole of the skimmer (i.e. 5 cm below the return fitting hole).
- e. Using a sharp nail, punch the holes for the skimmer housing connection in the liner from the external side of the pool. Fix the other gasket from the internal side of the pool and attach the front plate. Insert the remaining 10 longer screws into the holes in the front plate and tighten them gradually using the Phillips screw driver.
- f. Using the sharp knife, cut the liner out from the front plate.
- g. Now install the return fitting.

### Assembly Instructions for the Return Fitting

- a. From the external side of the pool wall, using a sharp knife, cut a circular hole out of the liner for the return fitting connection via the pre-formed hole in the pool wall. The hole should be about 5-10 mm smaller than the pre-formed hole in the pool wall.
- b. Take the other hose coupler and screw it into the return fitting body. Use Teflon® tape for sealing (do not use adhesives or sealing putties).
- c. Insert the return fitting into the circular hole in the wall from the internal side of the pool so that one rubber gasket can be fitted from inside the pool and that one cork gasket and the other rubber gasket can be fitted from outside the pool. Tighten the return spring properly.
- d. Screw the locking nut with swivel head into the return fitting hole and align it so that it can face towards the hole of the skimmer.
- e. Connect the skimmer and the return fitting with the filter using the help of hoses. Secure the connections using the hose couplings.

## 3. OPERATING INSTRUCTIONS

- a. An optimum water level is the middle of the skimmer overflow.
- b. Clean the skimmer basket on a daily basis.
- c. The skimmer must not get frozen when filled with water. Winterise the pool before the advent of any frosts.
- d. The skimmer can also be operated also if the pool outlet is connected – see Annex C, Care for pool water.

### Return fitting adjustment

It is possible to adjust the direction of the water stream coming from the fitting – rotate the internal fitting ball into the required position. The water stream should be directed from the skimmer overflow hole. To achieve the optimum effect of drawing surface impurities into the skimmer, it is necessary that the water can “rotate” in the pool “.

## 4. WINTERISING

Proceed according to the instructions provided for in the Pool Instructions before the advent of frosts.

## **C) POOL MAINTENANCE**

---

Pool water does not only get contaminated with visible impurities (dust, leaves, sand, twigs...), but also micro-organisms (bacteria, algae, fungi and viruses). Even after washing, every swimmer deposits a vast number of impurities into a pool, such as sweat, hair, sebum and cosmetic and sunbathing lotion residue. Someone who has not taken a shower before entering the pool may bring an 600 million to 3.5 billion bacteria, germs and viruses into water. They subsequently form an ideal breeding environment for further bacteria, algae, fungi and viruses. For this reason, water must be treated on a regular basis to ensure sanitation is preserved.

### **MAIN PRINCIPLES OF POOL OPERATION**

#### **Filling of the Pool – Commencement of operation**

Before filling the pool, especially after winterising, the pool should be cleaned of all impurities (lime sediments, dust, organic residue). Proper cleaning of the pool makes water maintenance easier.

Fill the pool with water and set the filter in motion; keep it in operation for at least 24 hours. Remove solid larger impurities with a basket, and remove sediment on the bottom using the pool outlet. Immediately after filling with water, carry out the first treatment of water using appropriate chemicals. Consult a specialist pool chemical supplier for further information.

#### **Filtration and Mechanical Cleaning of the Pool**

Floating impurities can be removed from water by means of regular filtration. Carry out filtration only when the pool is not being used.

Excessive contamination of the pool by rough impurities (leaves, insects, sand, etc.), as well as algae, can be avoided by covering the pool with a cover when it is not being used. The amount of impurities can also be reduced by treating the surroundings of the pool accordingly. Remove these impurities either by using a handheld net if they are floating in or on the water, or by using the outlet if they are settled on the bottom. If there is excessive contamination at the bottom of the pool, we recommend using the outlet facility to empty the pool and then topping it up.

## Working with the Outlet

**Note:** The pool outlet is not part of the pool. Please contact your seller.

The outlet is designed to remove impurities settled on the bottom with the help of the filter. With the help of a hose and the outlet head, the pump propels the water stream into the filter, where impurities are caught.

- A. Remove the skimmer locking top. Switch the filtration unit valve to the position for filtration and turn on the filtration unit.
- B. Fill the outlet hose with water (e.g. with a water stream from the return fitting).
- C. Hold the free hose end under the water level and connect the plate to it. Wait until the water stream starts flowing from the plate and then insert the plate quickly into the skimmer housing and install it firmly above the skimmer basket. While installing the plate into the skimmer, do not interrupt the water flow in the hose and ensure that the first end of the hose is immersed in water all the time.

**Note:** If you want to use the outlet adapter, proceed as follows:

1. Remove the skimmer locking top and remove the overflow system flap valve (carefully in order to avoid damaging the flap valve). Insert the plate with the adapter installed (the adapter hole must remain submerged below the water level so that the filter can draw water) and direct the adapter towards the pool. Switch on the filter unit.
  2. Fill the outlet hose with water (e.g. with a water stream from the return fitting), and install the other end on the adapter inside the skimmer. While doing so, be sure that both ends remain below the water level.
- D. Connect the pool outlet onto the opposite end of the hose (which must be below the water level all the time).
  - E. Now you can start using the outlet. While using it, make sure the outlet head does not get above the water level and that the suction system does not get aerated. Draw impurities from the bottom slowly, as any sharp movement of the outlet will cause any settled impurities to blow around.
  - F. Once the suction phase is complete, please disconnect the hose from the plate and remove the plate from the skimmer housing.

At the end of the suction phase we recommend checking the filter to see whether it requires cleaning.

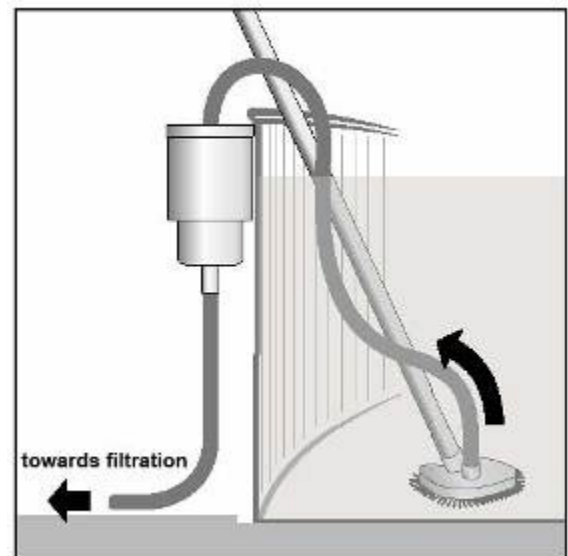

## Pool Cleaning

During the season various impurities will settle on the wall of the pool, ie: skin fat, cosmetics and sunbathing creams, sweat, dust, insects, leaves, seeds, grass straws, impurities from air and pool surroundings, as well as water hardness settled down. These impurities form a suitable environment for algae and bacteria formation. It is therefore recommended that the pool liner be cleaning thoroughly once a year, preferably in spring before filling with water.

